

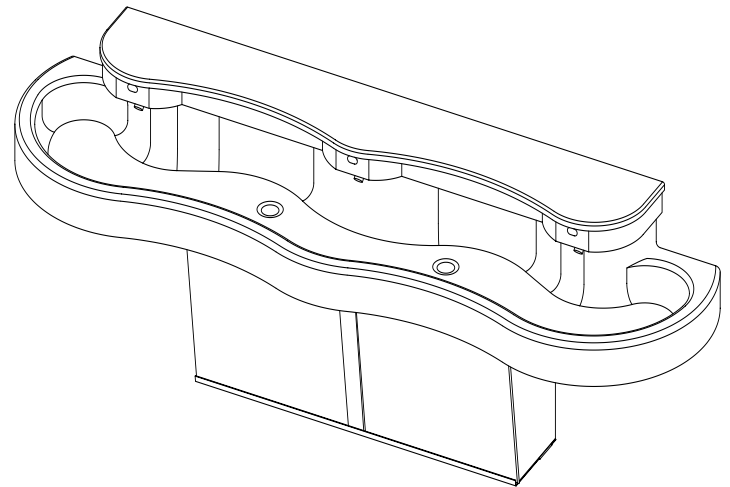

AquaWave® 3 Station Lavatory System



✓	MODEL NUMBER	NUMBER OF STATIONS	PEDESTAL TYPE
	WAW-2333	3	WALL

Recommended Specifications

Solid surface lavatory system shall be Willoughby AquaWave® Model No. **WAW-2333**.

AquaWave® Lavatory System shall accommodate from 1 to 3 users simultaneously. The lavatory system bowl, top, and pedestal panels shall be constructed of Aquasurf® molded cast polymer densified solid surface material composed of polyester/acrylic resin, UV stabilizer, aluminum trihydrate and mineral fillers. The pre-assembled water distribution heads and pedestal base shall be constructed of heavy gauge, type 304 stainless steel (the pedestal backplate is galvanized). Exposed stainless steel surfaces shall be polished to a satin finish. Pushbuttons and water spray nozzles shall be constructed of type 303 stainless steel. The drain grates shall be constructed of heavy gauge stainless steel. The pre-assembled sprayhead module shall be equipped with independent spray nozzles; each controlled by a separate pushbutton or infrared sensor. Flow restrictor shall maintain flow rates at 0.5 GPM per station. AquaWave® Lavatory Systems shall be supplied with thermostatic mixing valve, check stops and strainers, drain spuds, flexible supply hoses, control valves, color coded water lines, and (IR and EL1 valves only) Class II, 120/24 VAC plug-in transformer.* Operating supply water pressure range is 25-100 PSI.

Vandal Resistance:

All spray nozzles, pushbuttons, infrared sensors, and escutcheons are secured to the unit from within the sprayhead. Valves, water supplies, and waste connections are concealed within the pedestal. The pedestal panels are removable and secured with vandal resistant security screws. The Aquasurf® solid surface material is resistant to stains, impact, and burns. Surface damage can be easily repaired with everyday cleansers and/or fine grit abrasives.

ADA, UFAS, TAS, and ANSI Compliant:

When the lavatory system is mounted at the standard 34" rim height it is designed to comply with all applicable ADA, UFAS, TAS, and ANSI Z124.3 and Z124.6 accessibility guidelines.

Optional Features:

AquaWave® Lavatory Systems also offer liquid soap dispensers as optional accessories. AquaWave® Lavatory Systems can also be mounted at juvenile rim height (Low Profile Pedestal kit required to meet accessibility guidelines). A floor kit is available for an installation that requires an on-floor pedestal.

**Note: Plug-in transformer must be used with a ground fault interrupter (GFCI) receptacle to help prevent possible electrical shock.*

Visit our website at <http://www.willoughby-ind.com>

2210 West Morris Street • P.O. Box 21217 • Indianapolis, IN 46221

(317) 638-2381 • Fax: (317) 638-6110 • (800) 428-4065

MODEL NUMBER AND OPTIONS:

1.) Lavatory Model:

- WAW AquaWave™

2.) Base Model Number:

- 2333 3-Station Lavatory

3.) Pedestal Type:

- FLR Floor Kit
 LP Low Profile Pedestal

4.) Valve Selection:

- PM1 Single Temp. Pneumatic
 EL1 Single Temp. Electronic
 IR Infrared Sensor

5.) Solid Surface Color:

- B1 Bone
 GW1 Glacier White
 GG1 Grey Granite
 SS1 Sandstone
 WG1 White Granite
 BG1 Black Granite
 NB1 Nocturnal Blue
 RC1 Red Coral
 SG1 Sea Green

6.) Options:

- LSD Liquid Soap Dispenser
 TAS Texas Accessibility Standards (Modified Apron)
 JR Junior Height (28" Rim Height) (LP Pedestal Required)
 Other _____
 Other _____

To specify fixture and accessories, use the Model Number and Options Guide.

Example: To specify a 3 station AquaWave™ washbasin with a low profile pedestal, infrared sensor, in Sandstone color, and with liquid soap dispenser, use the following Willoughby Model Number:

Willoughby Model Number: WAW-2333-LP-IR-SS1-LSD

Drawing Approved For Manufacturing By: _____ Date: _____ Company: _____

Wall Thickness: _____ Wall Type: _____

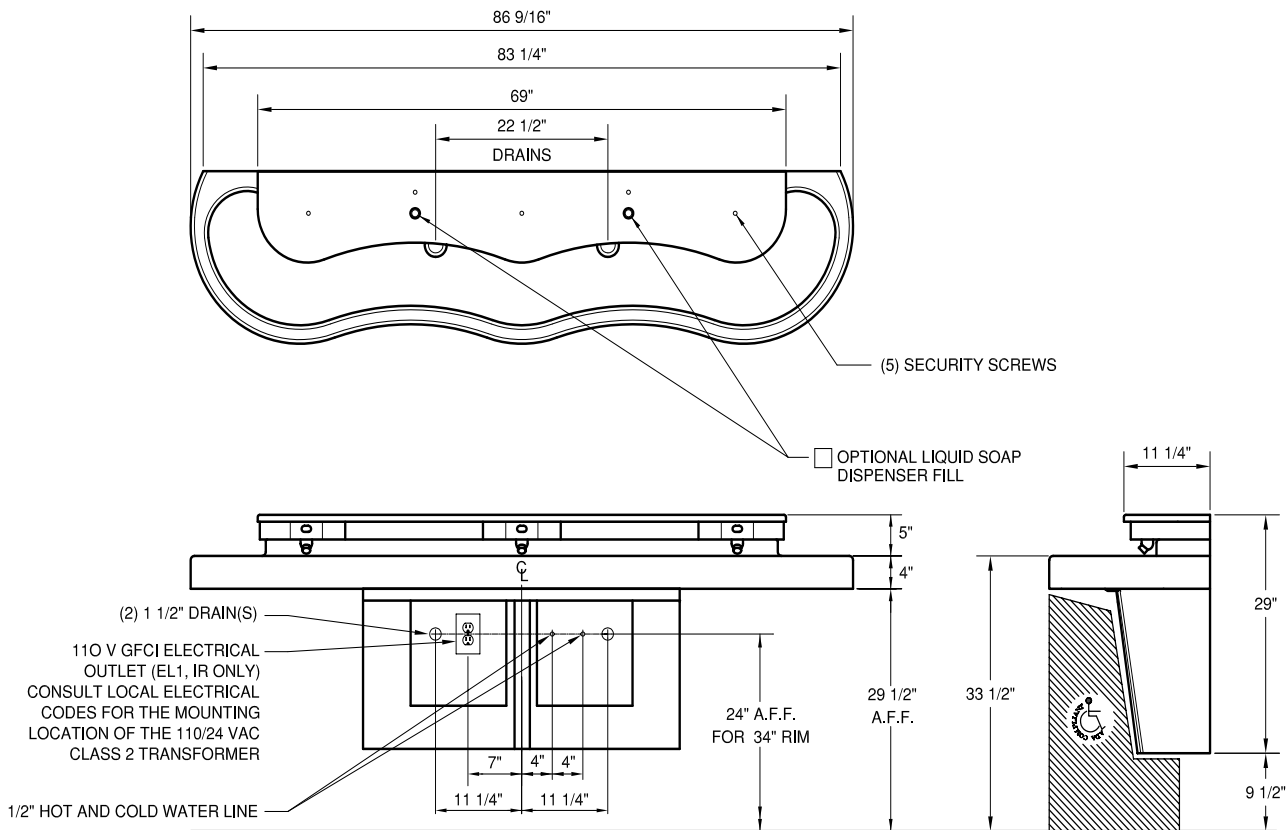

Willoughby Industries, Inc.