

Installation Instructions

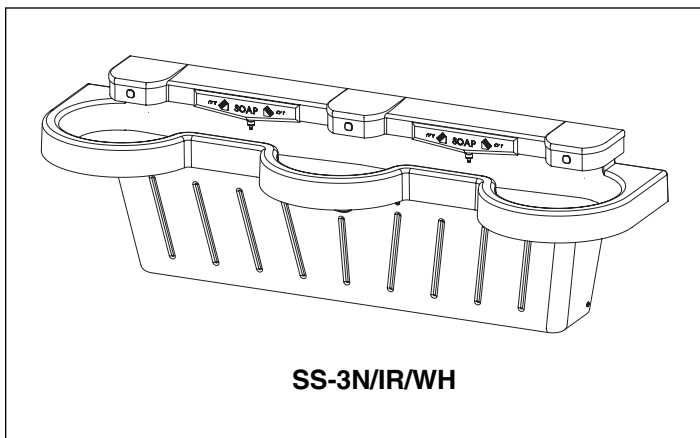
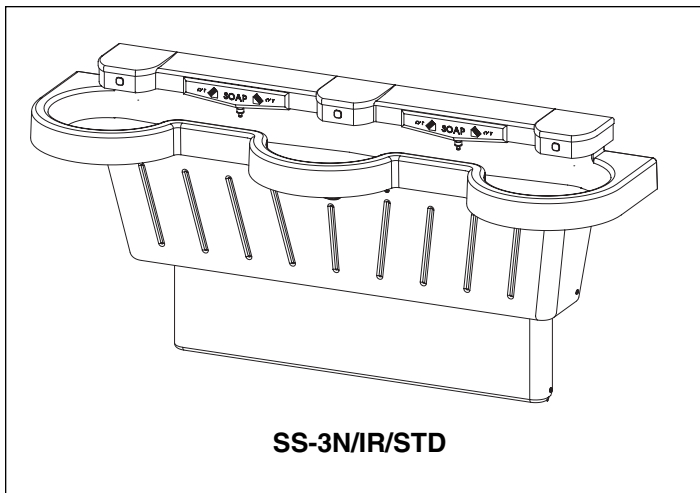

SS-3N/IR/STD
SS-3N/IR/WH

Express® Lavatory System SS-Series

(Standard and Wall-Hung Pedestals)

Express® Lavatory Systems are ADA and TAS compliant.



U.S. Patent Nos. 5,611,093, 5,369,818, D398,969
Other Patents Pending

Table of Contents

Pre-Installation Information	2
Dimensions	3-4
Installation Instructions	5-11
Cleaning and Maintenance	12
Soap Dispenser Maintenance	13-14
Assembly of Components	15-16
Solenoid Valve Troubleshooting	17-18
Vernatherm™ Mixing Valve	19-20



IMPORTANT

Read this entire installation manual to ensure proper installation.

Turn OFF electrical power to the outlet before installing the Express®.

Flush all the water supply lines before making connections.

Wall anchors used must have a minimum pull-out rating of 1,000 lbs.

File these instructions with the owner or maintenance department.

Product warranties may be found under "Product Information" on our web site at www.bradleycorp.com.



Pre-Installation Information

Barrier-free and ADA compliant - standard height mounting

The SS-3N/IR Express® Lavatory System must have a rim height of 34" above finished floor to be compliant with Americans with Disabilities Act (ADA). When mounted at 34" rim height, the Express® meets ADA, ANSI and UFAS requirements for barrier-free clearances, reaches and controls. Always check local codes and ordinances for compliance.

Barrier-free and ADA compliant - juvenile height mounting

The SS-3N/IR/WH Express® Lavatory System must have a rim height of 31" max. above finished floor to be compliant with Americans with Disabilities Act (ADA) Accessibility Guidelines for Buildings and Facilities: Building Elements Designed for Children's Use; Final Rule.

Texas Accessibilities Standards

The SS-3N/IR/WH Express® Lavatory System is designed to comply with Texas Accessibilities Standards for adults and children. Always check local codes and ordinances for compliance.

Infrared sensor and solenoid

Each sprayhead is controlled by a separate sensor and solenoid valve, enabling each user to activate a single flow of water. Each valve uses less than half the maximum of hot water allowed by the ANSI/ASHRAE/IES 90A-1980 Standard.

Supplies required for installation:

- (8) 3/8" wall anchors, bolts and washers (1" min. O.D.) to mount main frame and bowl to wall (minimum pull-out rating of 1,000 lbs.)
- STD. HEIGHT ONLY: (2) 3/8" wall anchors, bolts and washers to mount scuff base to wall
- 1/2" NPT hot and cold supply piping
- (2) 1/2" NPT street elbows
- 1-1/2" NPT drain piping
- 110 volt GFCI protected electrical outlet for 110/24 VAC plug-in transformer (supplied)
- 240/208-volt or 277-volt electrical box for optional electric tankless water heater

Express® Lavatory System Warranty

Bradley Corporation warrants to commercial and institutional purchasers only each unit free from defects in material and workmanship under normal use and service upon the following terms and conditions:

1. This warranty is limited to replacing or repairing, at our option, transportation charges prepaid by the purchaser, any Bradley unit or part thereof which our inspection shall show to have been defective within the limitations of this warranty.
2. The period during which Express® Lavatory System components are warranted is as follows:
 - Terreon® bowl and shelf warranted for five years
 - All other Express® Lavatory System components warranted for one year.
3. This warranty does not cover installation or any other labor charges and does not apply to any units which have been damaged by accident, abuse, improper installation or improper maintenance.
4. The replacement or repair of defective units as stated in this warranty shall constitute the sole remedy of the purchaser and the sole liability of Bradley Corporation under this warranty. Bradley Corporation shall not otherwise be liable under any indirect damages caused by defects in the repair or replacement thereof.
5. This warranty extends only to commercial and institutional purchaser and does not extend to any others, including consumer customers of commercial institutional purchasers.
6. This warranty is in lieu of all other warranties, expressed or implied, including any implied warranty of merchantability or fitness for a particular purpose or otherwise.

SS-3N/IR/STD and SS-3N/IR/WH Express® Lavatory System Dimensions

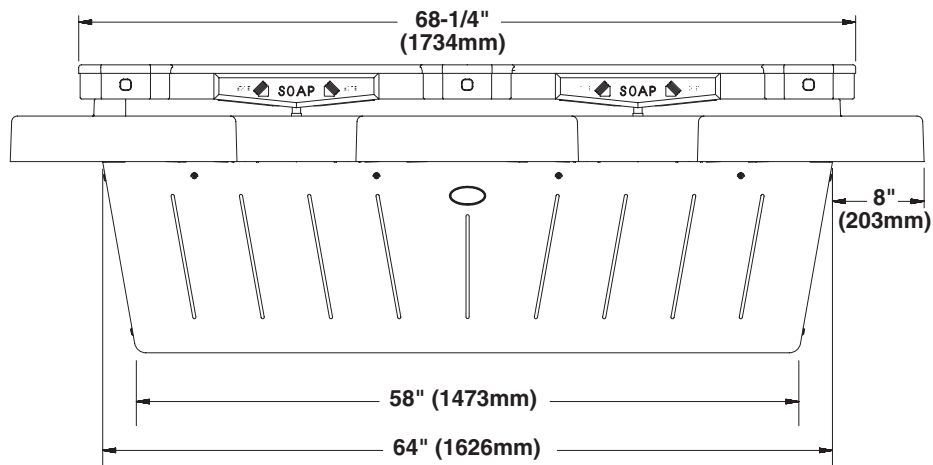
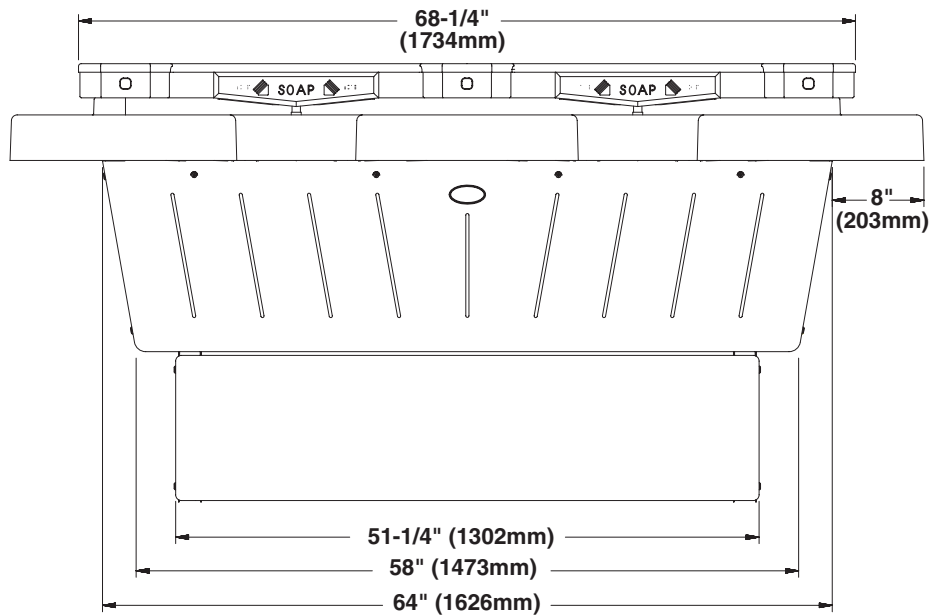
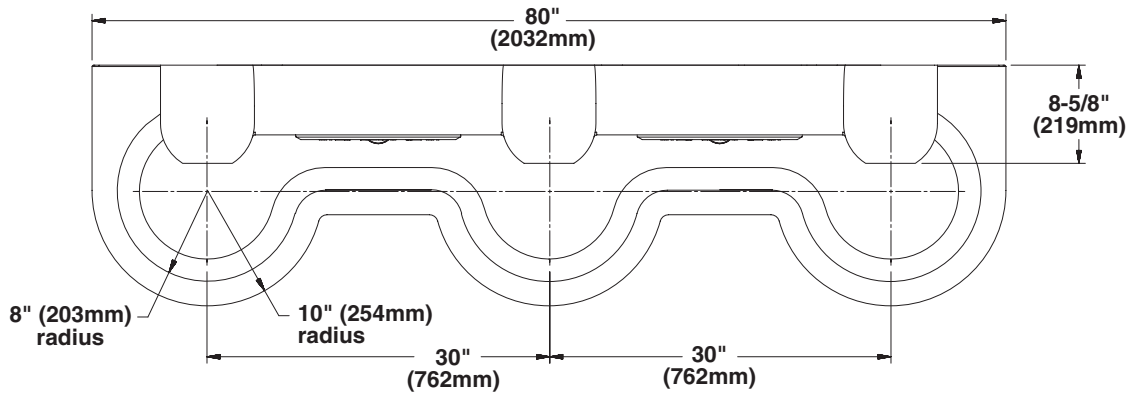

Express® Lavatory System Dimensions *continued* . . .

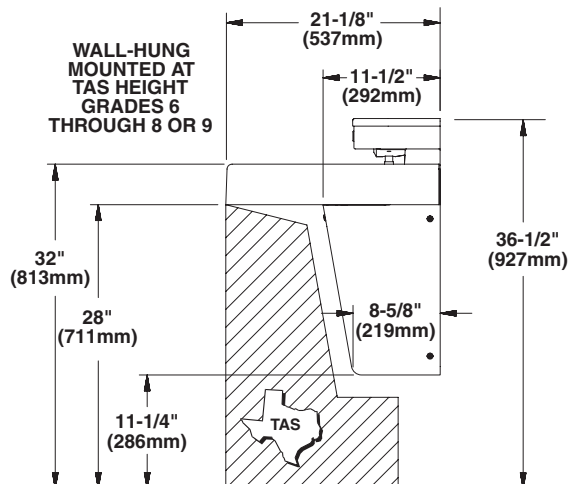
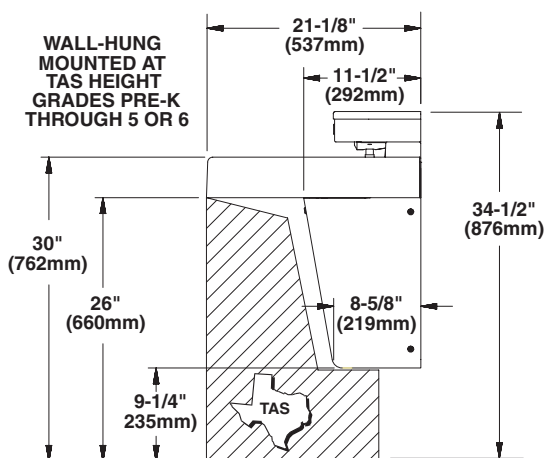
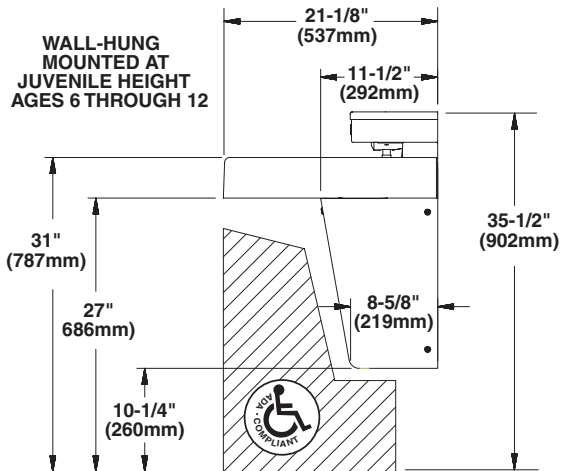
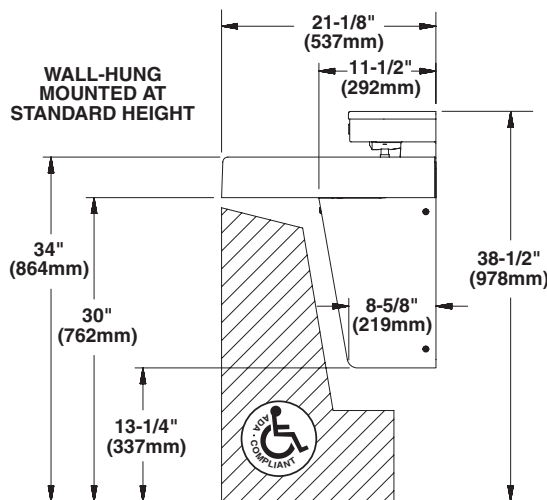
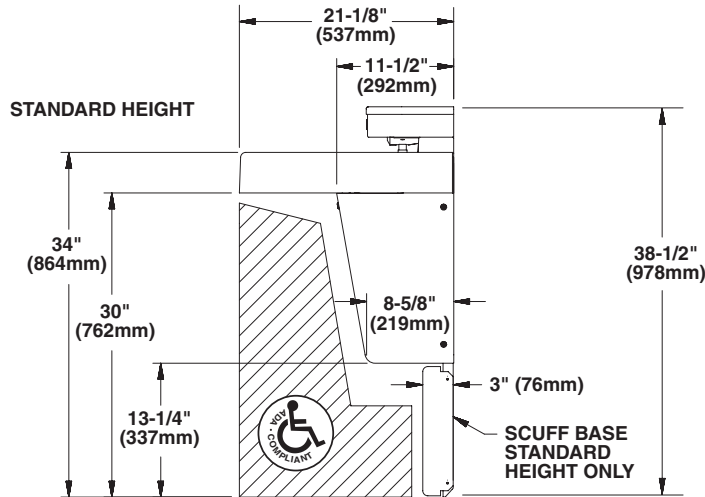

Installation Instructions

Step 1: Rough in



IMPORTANT: Flush the supply lines before making connections. Debris in supply lines will cause the valves to malfunction.



IMPORTANT: Dimensions shown in Figure 1 on page 6 are for a Standard and Wall-Hung Pedestal Express® only. Make sure to follow appropriate dimensions based on configuration and required rim height. See Charts 1 and 2 on page 6 prior to beginning rough-ins.

1. Rough in 1/2" NPT hot and cold supply lines through wall at dimensions shown.
2. Rough in 1-1/2" NPT drain waste connection through wall at dimensions shown.
3. OPTIONAL HOT WATER HEATER: Rough in appropriate electrical supply per local code (recommended 240/208-volt or 277-volt electrical box location shown on page 6).
4. Install the 110 volt GFCI electrical outlet per local code at the location shown in Figure 1.
5. Install six to eight 3/8" wall anchors with a minimum pull-out rating of 1,000 lbs. (supplied by installer) at the locations shown in Figure 1.
6. On the back of the bowl, measure the distance between the 3/4" bowl mounting holes. Divide this measurement in half. Measure and mark this dimension on the wall to the left of the centerline and to the right of the centerline. Install two 3/8" wall anchors with a minimum pull-out rating of 1,000 lbs. (supplied by installer) at the locations marked (ref. location "A" shown in Figure 1).

NOTE: Wall anchors at location "C" (standard frame only) do not require a minimum pull-out rating of 1,000 lbs.

NOTE: The anchors will be used to mount the Express® bowl and frame to the wall.

SS-3N/IR Express® Lavatory System Dimensions

MOUNTING FOR STANDARD AND WALL HUNG HEIGHTS ARE SHOWN

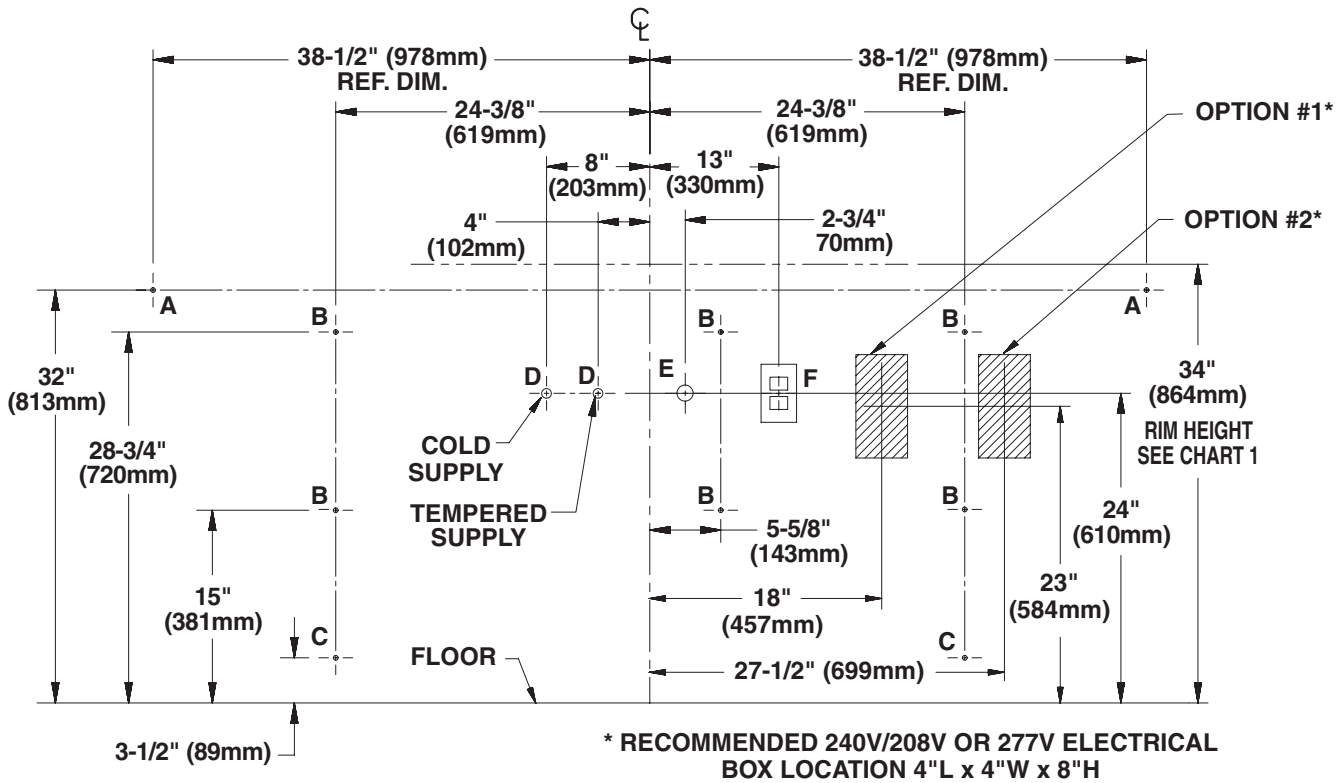

Figure 1

CHART 1

RIM HEIGHT	VERTICAL HEIGHT ADJUSTMENTS "A" THROUGH "F"	FIXTURE STYLE
34"	NONE	STANDARD HEIGHT
34"	NONE	WALL HUNG
32"	SUBTRACT 2"	TAS, GRADES 6 THROUGH 8/9
31"	SUBTRACT 3"	JUVENILE HEIGHT
30"	SUBTRACT 4"	TAS, PRE-K THROUGH 5/6

CHART 2

CODE	DESCRIPTION	QTY.
"A"	3/8" BOWL WALL ANCHORS WITH A MINIMUM PULL-OUT FORCE OF 1,000 lbs.	2
"B"	3/8" MAIN FRAME WALL ANCHORS WITH A MINIMUM PULL-OUT FORCE OF 1,000 lbs.	6
"C"	3/8" BASE FRAME WALL ANCHORS, STANDARD FRAME OPTION ONLY.	2
"D"	1/2" NPT HOT/COLD SUPPLIES, STUB OUT 2" FROM WALL.	2
"E"	1-1/2" NPT DRAIN, STUB OUT 2" FROM WALL.	1
"F"	110V GFCI PROTECTED ELEC. OUTLET.	1

Installation Instructions *continued . . .*

Step 2: Mounting frame to wall

1. Using a T20 Torx key, remove the eight #10-24 flat head Torx screws and #10 finish washers securing the access panel to the main frame, and remove the panel (see Figure 2).
2. Position the main frame against the wall, ensuring that it is level.



IMPORTANT: Anchoring the frame to a wall that is *not* flat may cause the frame to bend, making it difficult to reinstall the access panels.

3. Ensure that the back of the main frame is flat against the wall.
4. Once you have positioned the main frame such that it is level and flat against the wall, use the 3/8" bolts and 1" min. O.D. washers to mount the main frame to the wall (see Figure 3).
5. When mounting the standard height frame, mount the scuff base to the wall at the same time (using two additional 3/8" bolts and washers mentioned in Step 1, procedure #4 on page 5) (see Figure 3).

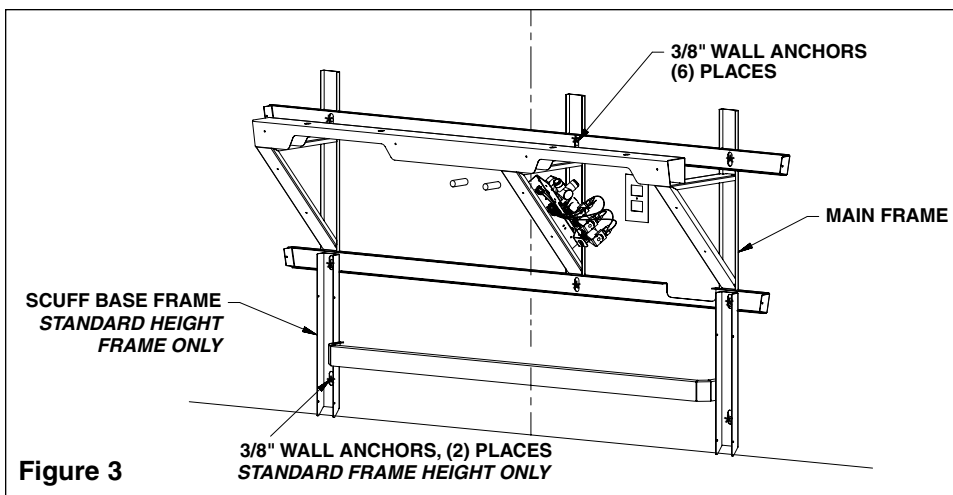
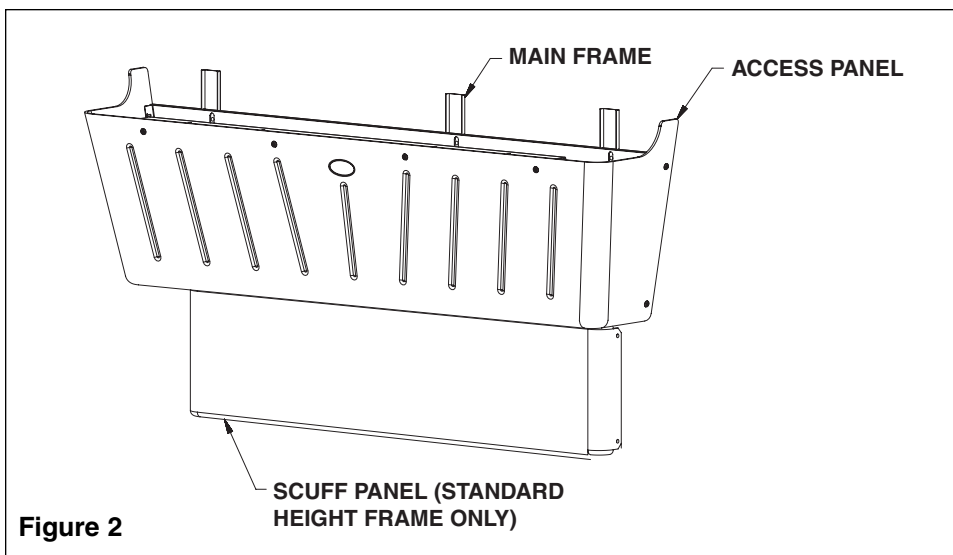

Installation Instructions *continued . . .*

Step 3: Installing bowl assembly

WARNING: To prevent serious injury and/or damage to the bowl, move and position the bowl with the assistance of another person and always use appropriate lifting procedures.

NOTE: Refer to Figure 4 below when installing the bowl assembly.

NOTE: The sprayhead body has slotted holes for adjusting the fit-up with the bowl and wall.

NOTE: The tailpiece on the waste tee has been rotated upward for shipping purposes. Turn the tailpiece down to its proper position before installing the bowl.

1. With someone to assist you, place the bowl assembly squarely onto the frame.
2. Attach the front underside of the bowl assembly to the frame using the four 1/4"-20 x 1/2" pan-head screws and washers provided. **Do not tighten bolts at this time.**

IMPORTANT: When bolting the bowl assembly to the frame and wall, do not overtighten bolts. Overtightening bolts can damage the Terreon® material.

3. After the bowl assembly is attached to the frame, use 3/8" bolts and 1" min. O.D. washers (supplied by the installer) to bolt the bowl to the wall anchors, two places.
4. Tighten the screws installed in procedure #2 above to secure the bowl assembly to the frame. **Do not overtighten.**

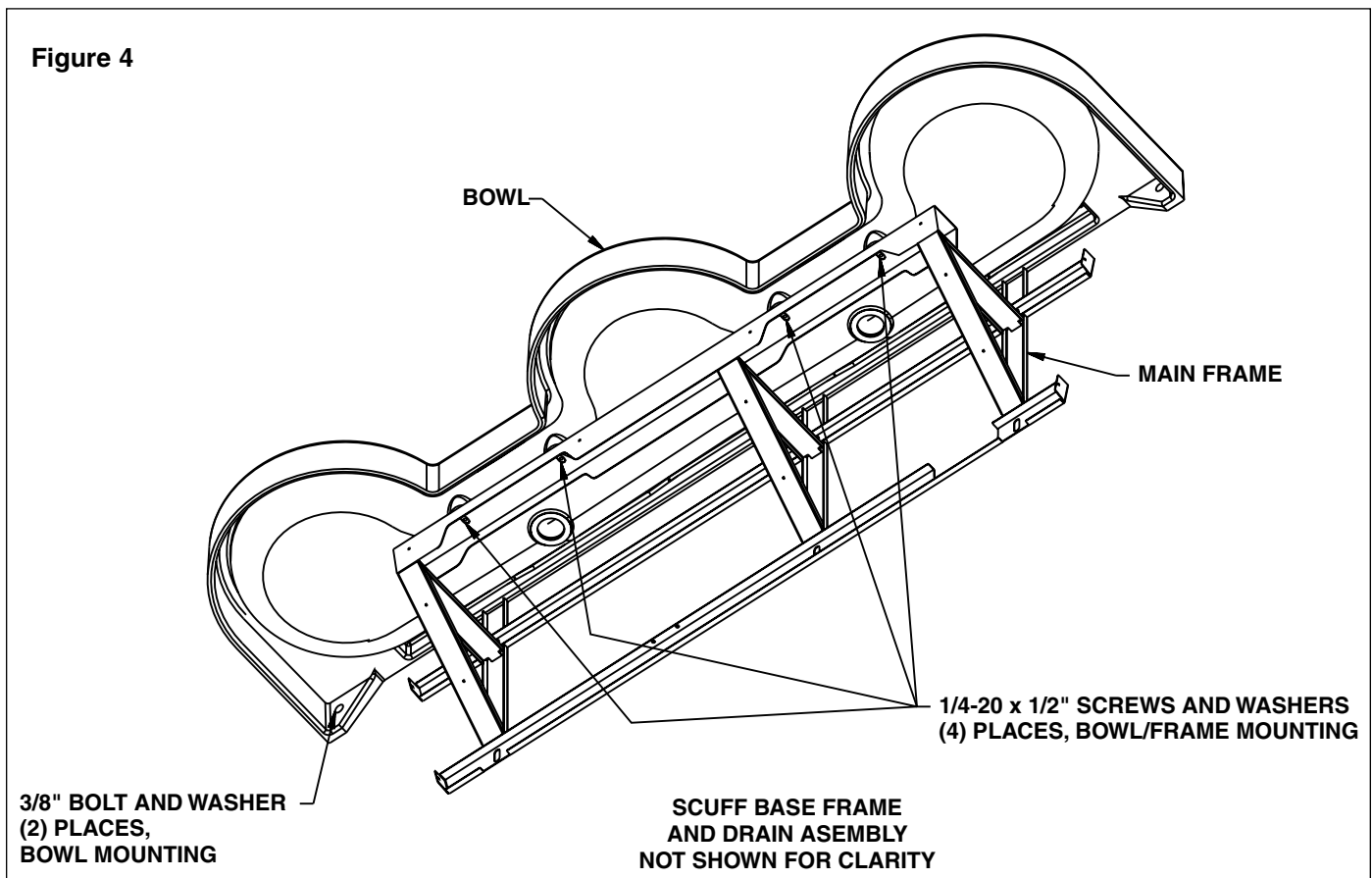

Installation Instructions *continued . . .*

Step 4: Connecting supply and drain

1. Loosen but do not remove the two mounting screws holding the valve bracket to the frame. Slide the valve bracket up until the larger cutout in the frame's slot aligns with the screw head (see Figure 5b). Then lift up to remove the valve bracket from the frame.
2. FOR HOT AND COLD SUPPLY: Using a thread sealer, thread the stop/check valve onto the hot and cold wall stub-outs (see Figure 5a). Attach one end of the 1/2" flexible hose to the Vernatherm™ valve (one hose on the hot side, the other hose on the cold side) (see Figure 5a). Attach the other swivel end to the stop/check valve (located on the wall stub-out).

NOTE: The letter "H" on the Vernatherm™ Mixing Valve indicates hot water supply inlet.

FOR SINGLE TEMPERED SUPPLY: Using a thread sealer, thread the stop/check valve onto the wall stub-out. Attach one end of the 1/2" flexible hose to the tempered line adapter and the other end to the stop/check valve located on the wall stub-out (see Figure 5c).

3. Assemble the P-trap by connecting the 1-1/2" tubular pipe to the tailpiece and to the 1-1/2" drain pipe stubbed out of the wall.

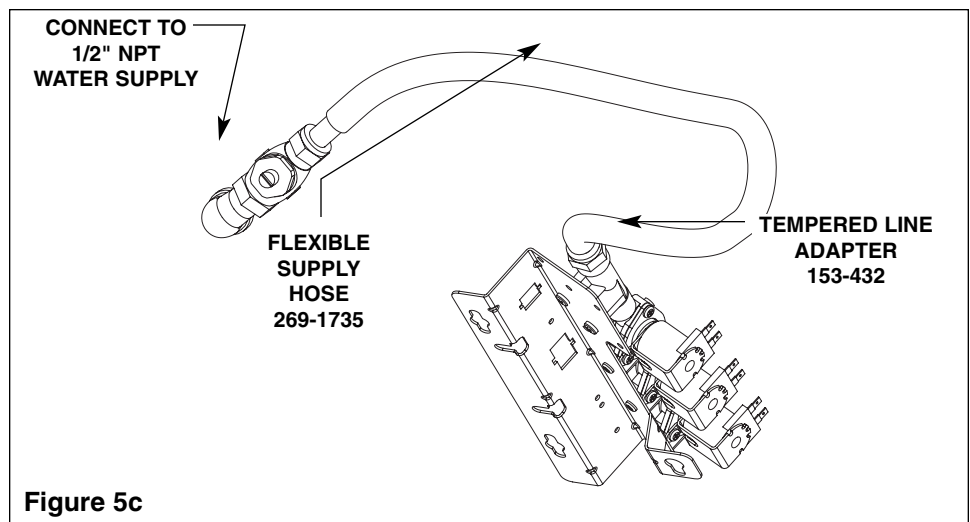
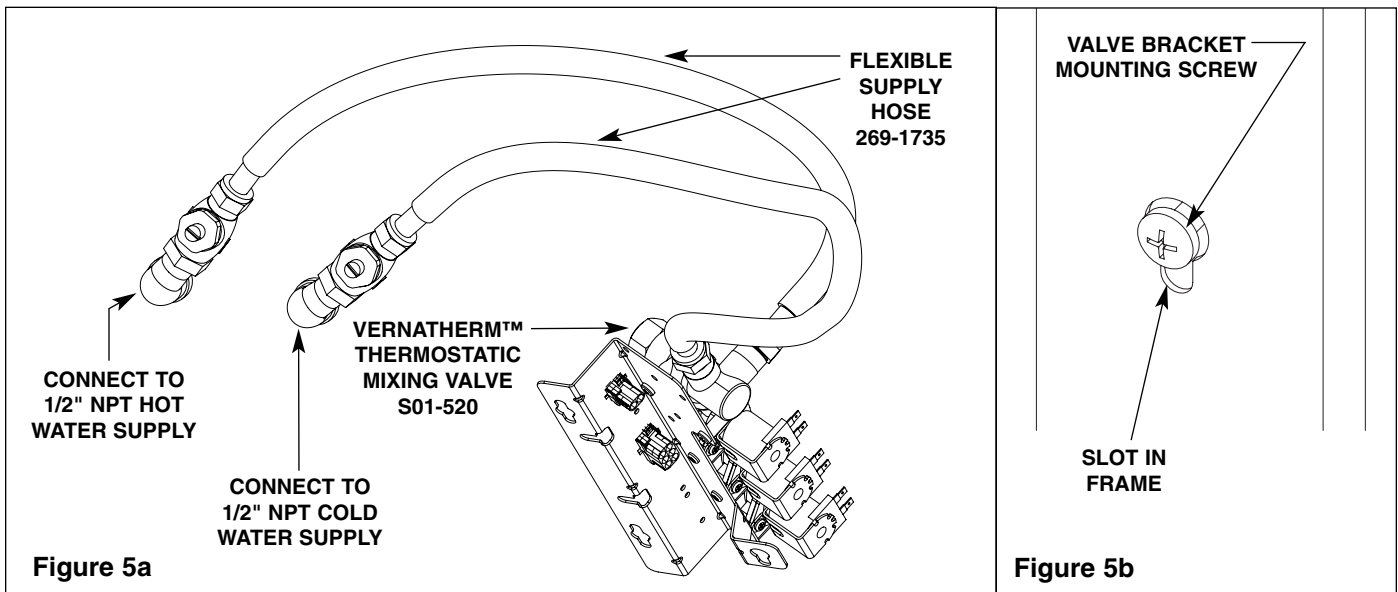

Installation Instructions *continued* . . .

Step 5: Connecting optional hot water heater

NOTE: 240/208 or 277 voltage is required for hot water heater. Refer to the installation manual provided with the hot water heater for further installation information.

1. Remove the cover from the water heater. Attach the bracket to the cover with the two screws, nuts and washers, then reattach the cover (see Figure 6a).
2. Hang the water heater on the right side frame member (see Figure 6b).
3. Connect the 1/2" flexible hose from the cold water supply stub-out to the hot water heater inlet.
4. Connect the 1/2" flexible hose from the hot water heater outlet to the supply inlet on the solenoid valve assembly.

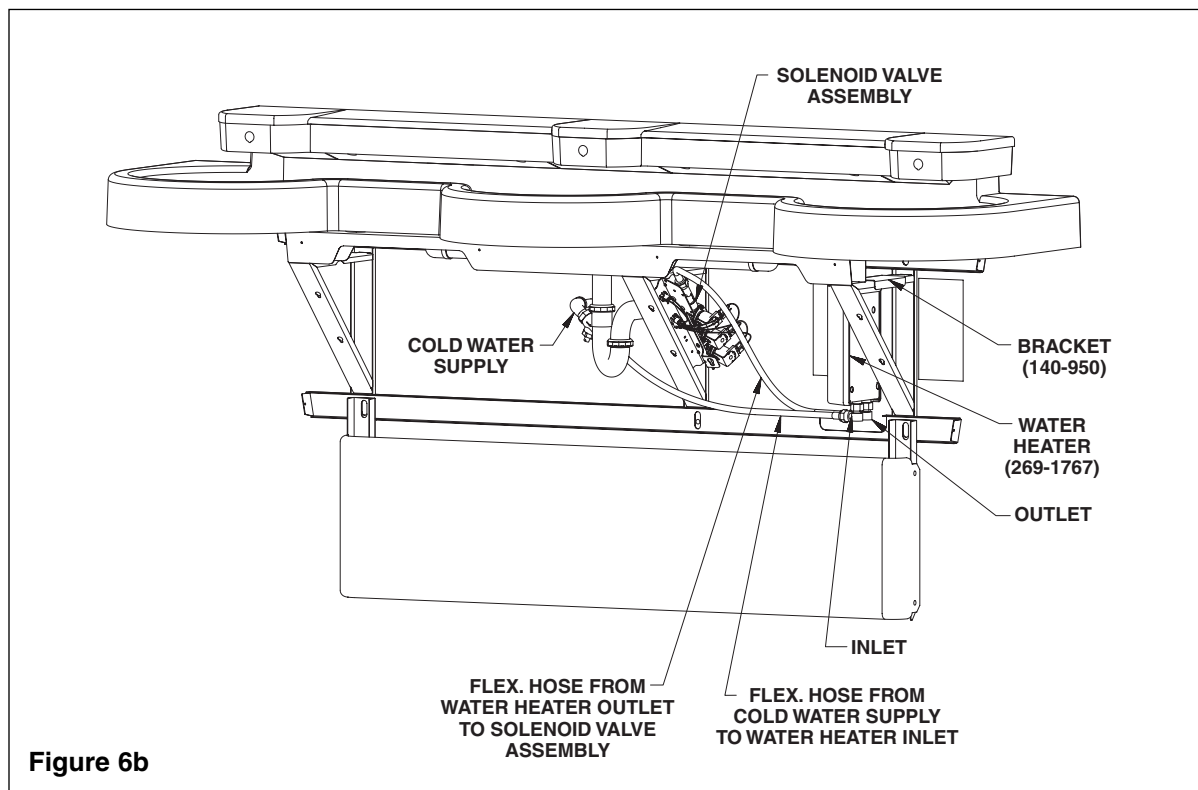
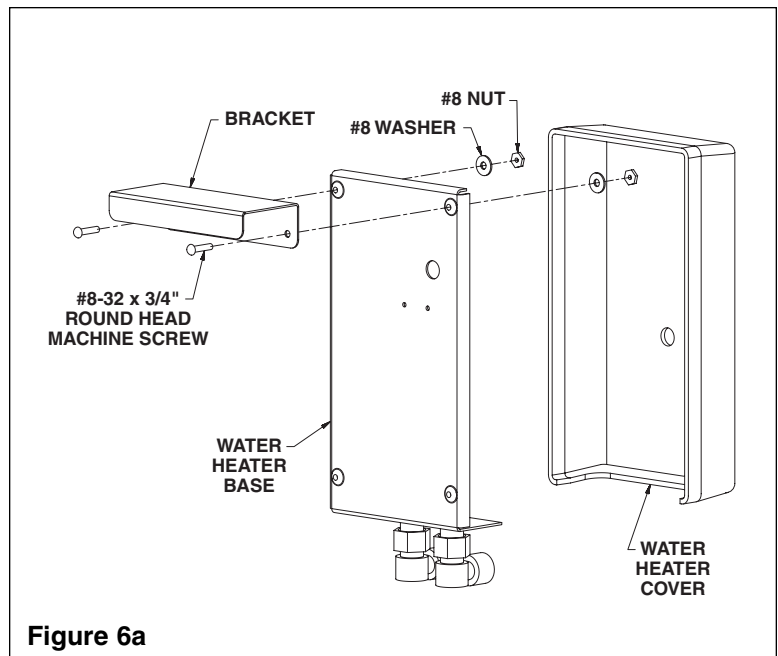

Installation Instructions *continued . . .*

Step 6: Connecting electrical and supply tubing

⚠ WARNING: The Express® must be connected to the 24 VAC Class II plug-in transformer provided. Connection to 110 VAC can result in personal injury and/or damage to the electronics.

⚠ CAUTION: Connection of leads other than shown may cause permanent damage to the sensor.

1. Snap the sensor circuit plug from the sprayhead into the solenoid circuit plug located on the valve bracket.
2. Snap the transformer circuit plug into the female transformer circuit plug located on the valve bracket.
3. Insert the three sprayhead supply tubes into the three solenoid tube connectors by loosening the compression nut and firmly pushing the tubing into the tube connector until the tubes are fully seated, then re-tighten the compression nut hand-tight plus two turns with a wrench. (Figure 7).
4. Align the valve bracket mounting screws with slots on the frame. Let the valve bracket slide down to lock into place.
5. Turn on the water supply to the Express® and check for leaks.
6. Turn on the electrical power to the electrical outlet and pass your hand in front of each station's sensor until all the air is purged from the lines and water is flowing smoothly.
7. After testing is complete, reinstall the main frame access panel to frame. Fasten panel with the eight #10-24 x 1/2" flat head Torx screws and #10 finish washers provided (Figure 3, page 7).

NOTE: For Express® units with optional soap dispensers, see pages 13 and 14 for soap dispenser maintenance instructions.

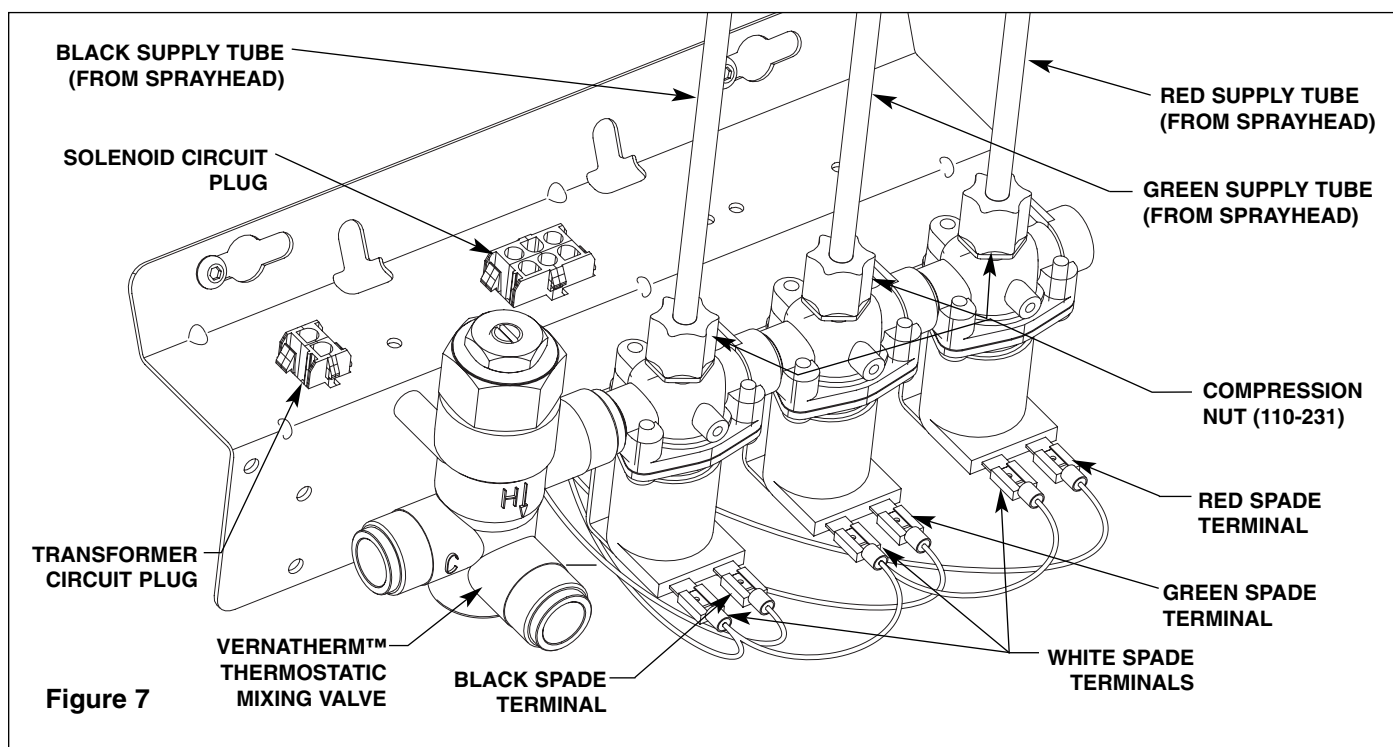

Cleaning and Maintenance Instructions

 **IMPORTANT:** Strong alkaline or acid-based chemicals and cleansers should not be used to clean Terreon®. If these chemicals come in contact with the Terreon® surface, wipe off the surface immediately and flush with soapy water.

Terreon® and panel maintenance

The bowl and sprayhead panel are constructed of Terreon®, a densified solid surface material composed of an acrylic modified polyester resin. Terreon® is resistant to chemicals, stains, burns and impact. Surface damage can be easily repaired with everyday cleaners or fine grit abrasives. The panel and sprayhead body are made of an acrylic/ABS laminate, and will not chip, peel or flake. With regular cleaning, your Terreon® fixture will provide years of dependable service.

Cleaning

- **Daily Cleaning:** Wipe the surface with a damp cloth and wipe dry.
- **Weekly Cleaning:** Wipe the surface with a damp cloth and a household liquid detergent. Stubborn stains can be removed as follows:
 1. Using a #7448 Scotch-Brite® pad, scrub with an abrasive cleanser such as Ajax®, Comet® or Soft Scrub® and water.
 2. Clean thoroughly with soapy water and allow to dry.
- **Scorch Marks:** Although Terreon® will not burn, a lit cigarette in contact with Terreon® could leave a scorch mark. Scorch marks can be removed by buffing with a #7448 Scotch-Brite pad or with an abrasive cleaner.
- **Repair kit:** In the unlikely event your Terreon® surface becomes damaged, it can easily be repaired. Contact your Bradley representative to order a repair kit and be sure to specify color when ordering.

Panel cleaning

 **IMPORTANT:** Do not use abrasive cleansers to clean the panel or sprayhead body. Abrasive cleaners can mar the surface.

- **Graffiti/Vandalism:** If vandals create markings on the panel, Bradley recommends using Motsenbocker's LIFT OFF® to remove ink and spray paint. Remover #3 is for ink and markers, and Remover #4 is for spray paint. Motsenbocker's LIFT OFF® can be ordered through Sanitary Maintenance Service Inc. (call 1-800-451-5523 x 425 or visit www.sanitarymaintenance.com/product.htm for ordering information). After cleaning with LIFT OFF®, give the panel a final thorough cleaning with a liquid tub and tile cleaner to remove soil and maintain the glossy finish.

NOTE: Use of brand names is intended only to indicate a type of cleaner. This does not constitute an endorsement, nor does the omission of any brand name cleaner imply its inadequacy. Many products named are regional in distribution and can be found in local supermarkets, department and hardware stores or through your cleaning service. It is emphasized that all products should be used in strict accordance with package instructions.

Soap Dispenser Maintenance

Step 1: Fill soap dispensers

The soap valves will dispense vegetable/coconut oil liquid soaps, synthetic detergents, viscous lotion soaps, and antiseptic solutions. A 10-15% concentration is recommended for vegetable or coconut oil liquid soaps. Synthetic detergents, lotion soaps, and antiseptic soaps require no dilution.

1. Using two screwdrivers (or similar tool), push up on the release tabs located beneath each soap dispenser and pull out the soap tanks from the sprayhead (see Figure 8a).
2. To remove packing dust, rinse out each soap tank with hot water. Shake water out thoroughly and allow to dry.
3. Pour the soap into each soap tank's filler hole (see Figure 8b).
4. After each soap tank is filled, position the soap tanks into the sprayhead openings and push into place.

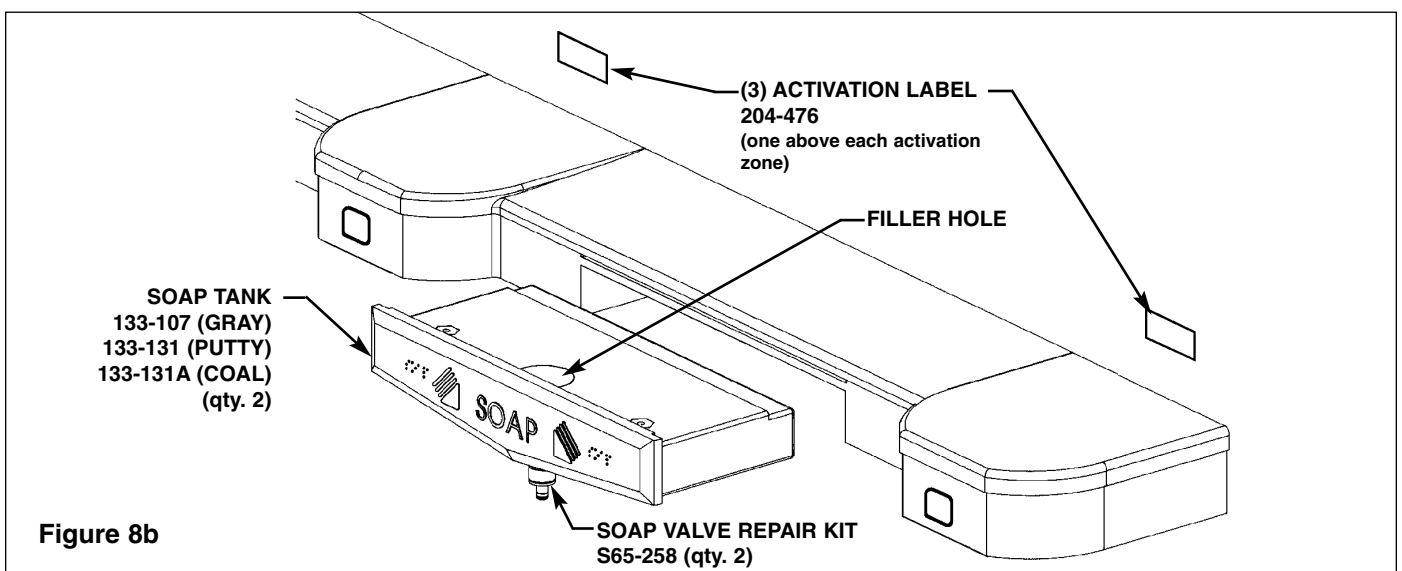
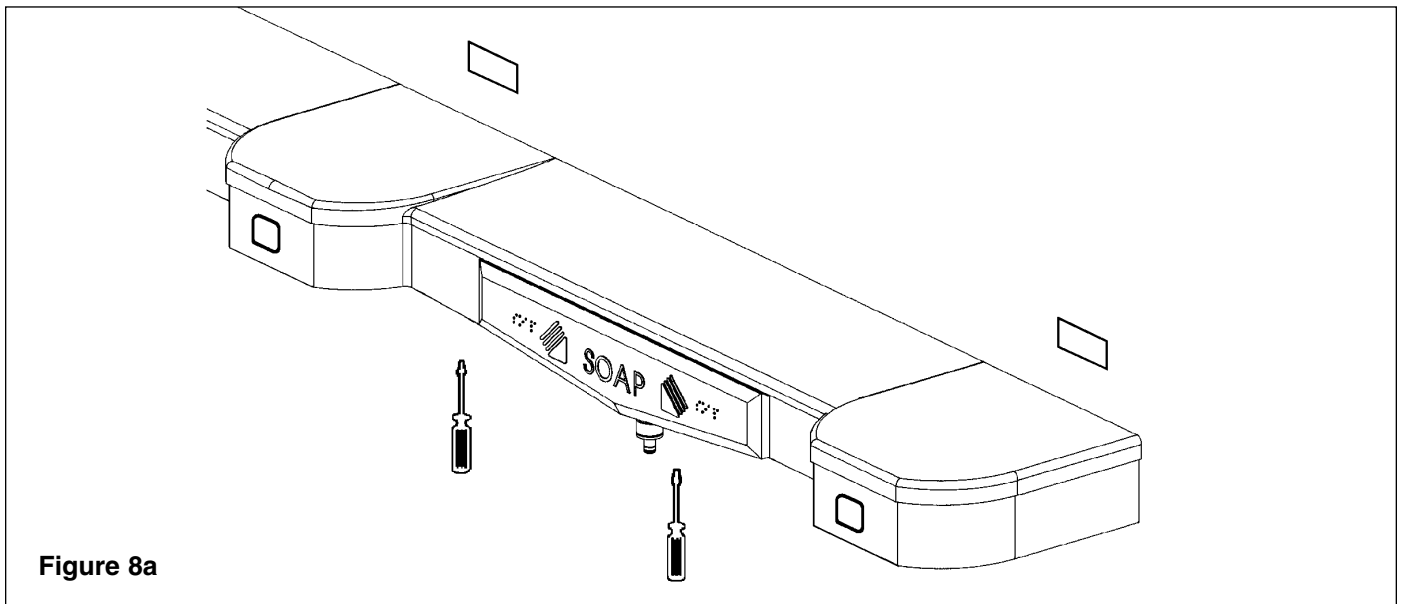

Soap Dispenser Maintenance *continued* . . .

Step 2: Change soap type

1. Pour out all of the soap from the dispenser.
2. Rinse the soap dispenser with hot water several times until all of the residue is removed, and pump the valve until clean water appears.
3. Rinse the dispenser with ethyl alcohol and allow to air dry.
4. After the dispenser is dry, pour the new soap into the soap dispenser.

Step 3: Cleaning Instructions

Regular cleaning of the soap dispenser is recommended to ensure optimum performance and maximum service life. Cleaning the soap dispenser monthly to remove soap residue, dirt, and other accumulations should become a regular part of your washroom cleaning routine and general maintenance program.



IMPORTANT: Do not use abrasive cleansers to clean the soap tank. Abrasive cleaners can mar the surface.

Clean exterior: Use warm water and soap to clean the exterior of the soap dispenser. Dry with a soft cloth.

Clean interior: Inspect the interior of the soap tank for residue or coagulation of soap. If necessary, clean the soap tank according to the following procedure:

1. Pour out any remaining soap in the tank.
2. Fill the tank half-full of hot water and shake the tank to dislodge the soap residue.
3. Empty the water from the container and repeat steps 1 and 2 until the soap container is clean.

NOTE: If rinsing alone does not remove the soap residue, place a small chain (24 inches long) into the soap tank with hot water and shake the container until the chain dislodges the residue. Then remove the chain and rinse out the soap tank.

Clean internal components: To clean the internal components of the soap dispenser, pump hot water through the soap dispenser until a clean flow of water comes out of the valve.

Assembly of Components

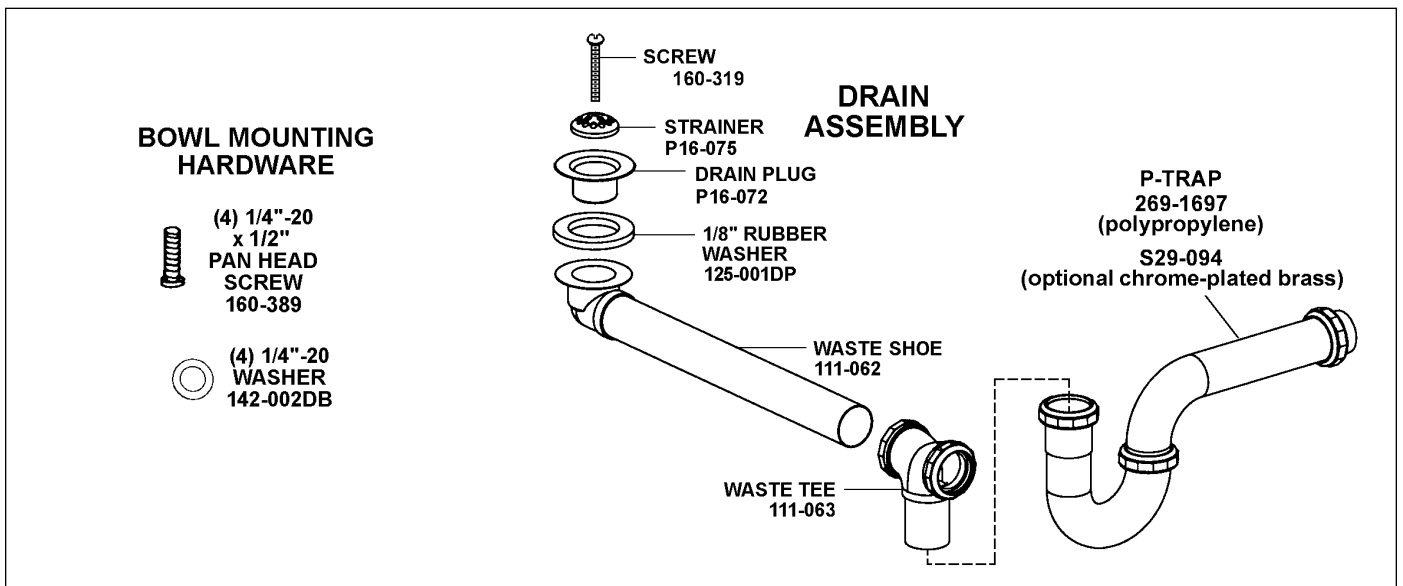
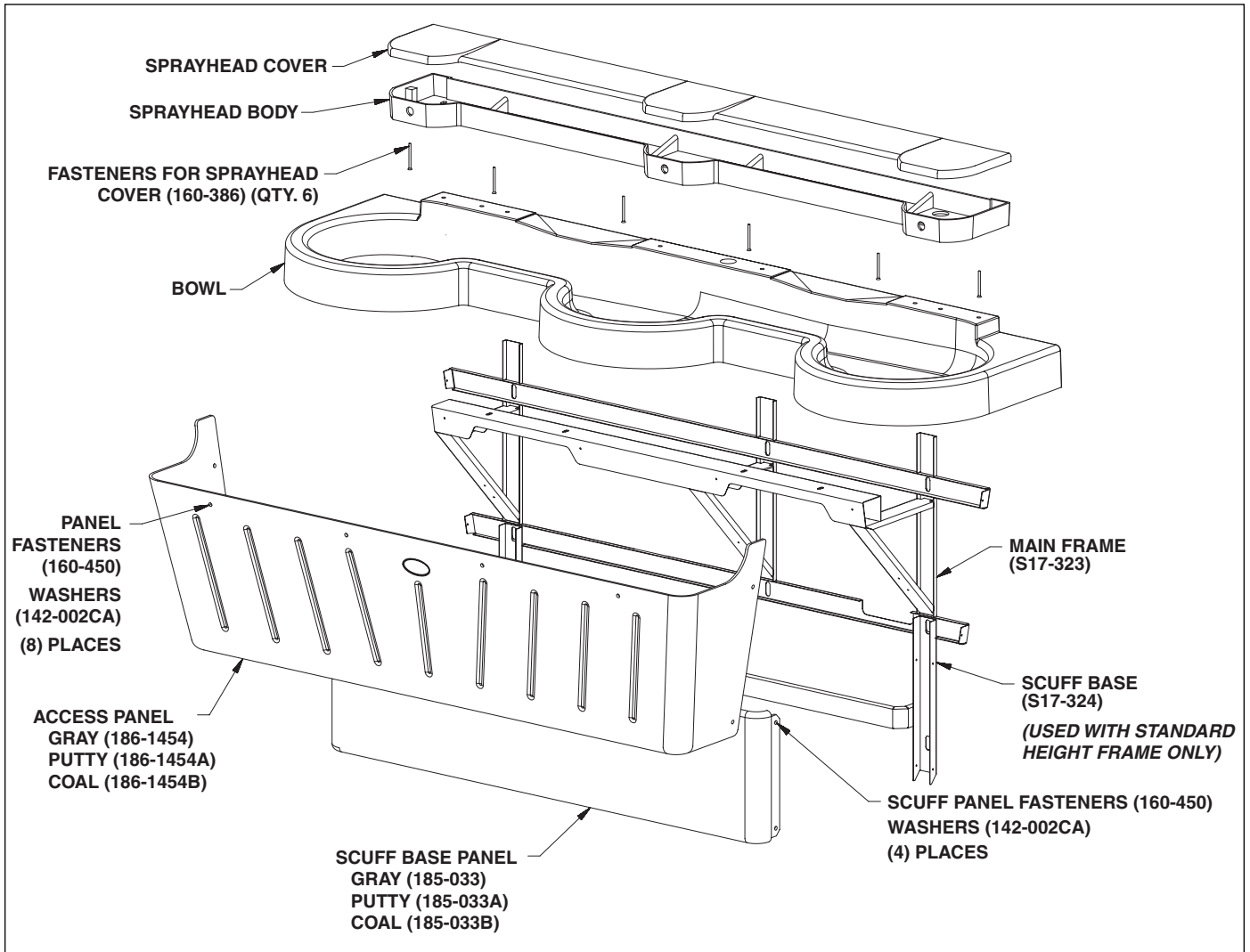

Assembly of Components *continued* . . .

Sensor assembly and solenoid valve

To access solenoids and sensors: Remove the six Phillips-head screws located in the bottom of the sprayhead body and lift the cover/shelf off (see components illustration on page 15 for locations).

To re-install sprayhead cover/shelf: Position the cover/shelf on the sprayhead body and secure it to the sprayhead body using the six screws provided.

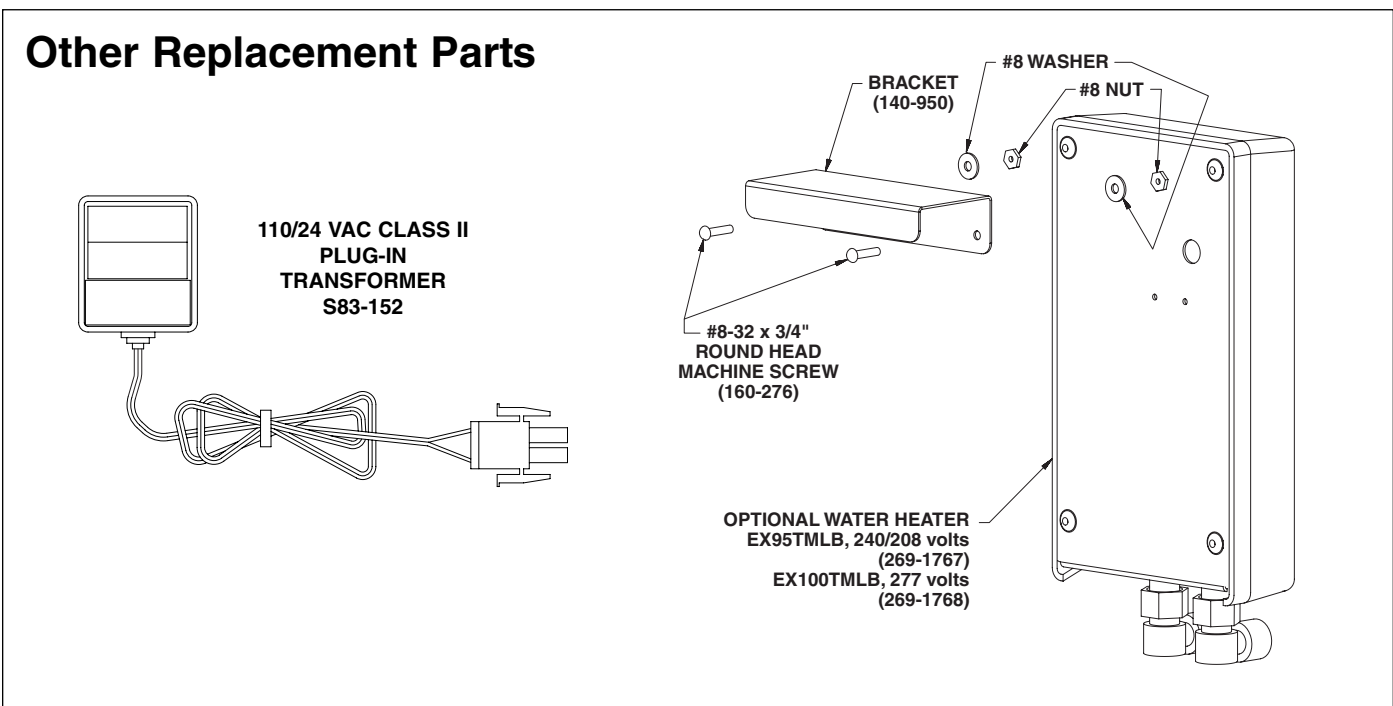
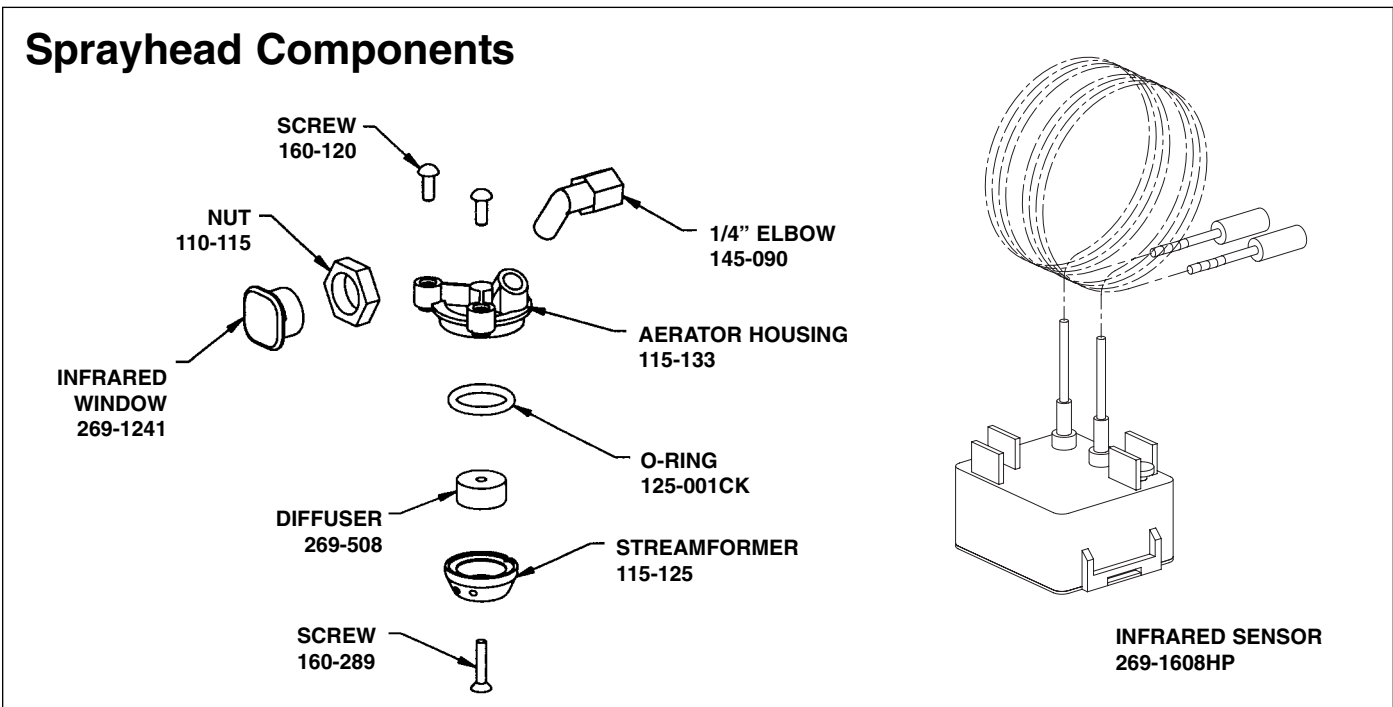

Troubleshooting Solenoid Valve (VAC)



CAUTION: Turn off water supplies to unit before troubleshooting.

Problem: An individual operating station fails to shut off and drips.

Cause: There is debris trapped between the diaphragm and the valve seat.

Solution: Remove debris between diaphragm and the valve seat.

1. Remove the three #8 Phillips-head screws that hold the solenoid valve assembly together. Be careful not to lose the armature or spring (see Figure 9 on page 18).
2. Remove the diaphragm. Remove any particles that have been trapped between the diaphragm and the valve seat. Rinse off the diaphragm and inspect for damage. Make sure the center orifice and both small side orifices are open.
3. Reassemble in reverse order, being careful not to overtighten the Phillips-head screws or you may crack the plastic valve body. Tighten until the armature plate makes contact with the plastic body.
4. Reconnect the wiring per diagram on page 11

Problem: An individual operating station fails to turn on.

Cause: A failed coil for the valve or loose electrical connection to the terminal.

Solution: Test the station to determine cause.

1. Disconnect the wires from the coil of an adjacent valve. Disconnect the wires from the problem valve and reconnect to the adjacent valve.
2. Turn on electrical and water supplies to the unit. Pass your hand in front of the sensor of the problem station, and the adjacent station should turn on.

If the adjacent station turns on and cycles normally, replace the coil on the problem valve.

If the adjacent valve fails to turn on, inspect the wires from the sensor cable and do the following:

- make sure there are no breaks and that the fully insulated disconnect terminals are firmly crimped in place;
- turn off the electrical and water supplies;
- reconnect to the adjacent valve and turn on the water supplies to the unit;
- pass your hand in front of the sensor. If the station still fails to turn on, replace the sensor (see page 16).

Solenoid Valve S07-068 (closed body) and S07-068A (thru body)

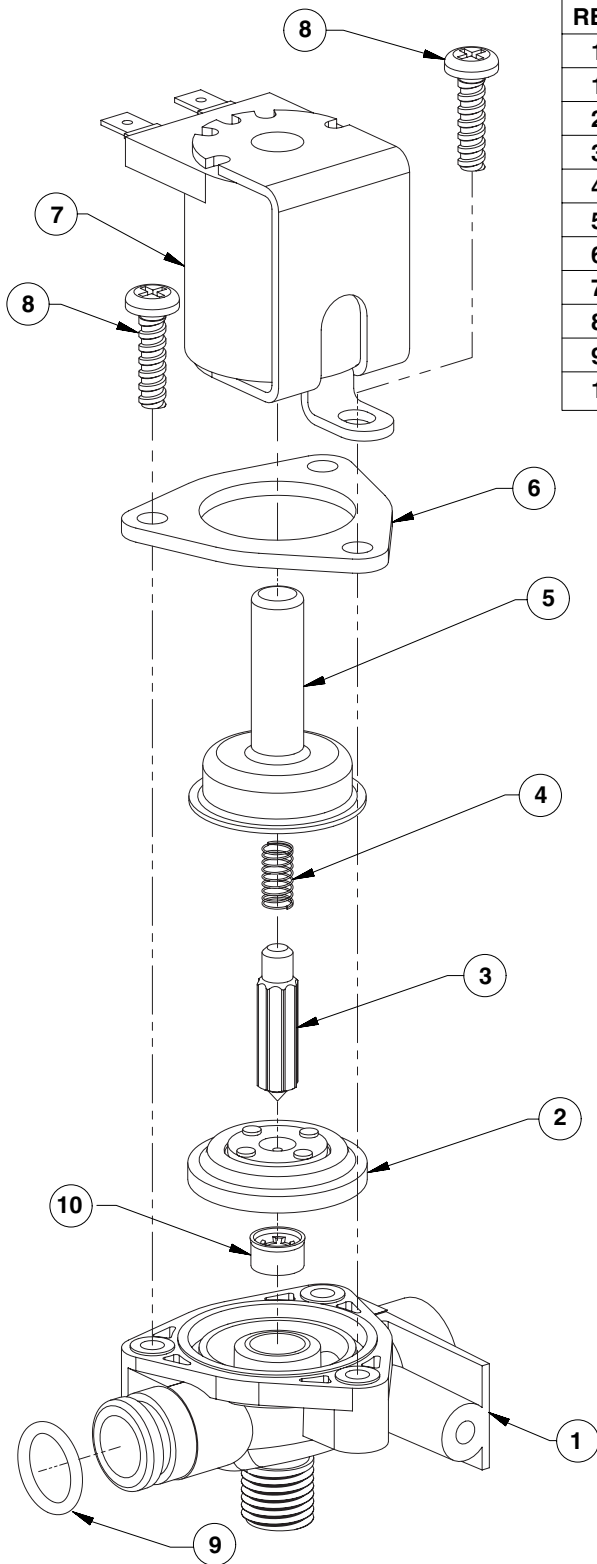

REF.	QTY.	PART NO.	DESCRIPTION
1	1	118-307	VALVE BODY, 1/4" CLOSED
1	1	118-307A	VALVE BODY, 1/4" THRU
2	1	269-983	DIAPHRAGM
3	1	269-577	ARMATURE
4	1	269-578	SPRING
5	1	269-1729	ARMATURE HOUSING
6	1	269-1730	CLAMP, ARMATURE HOUSING
7	1	269-579	COIL, SOLENOID VALVE
8	3	160-447	SCREW, #8 X 5/8
9	1	125-001CS	O-RING, #2-013
10	1	125-160	FLOW RESTRICTOR, .5 GPM

Figure 9

Thermostatic Mixing Valve Maintenance and Troubleshooting

NOTE: Before attempting to troubleshoot the valve or disassemble the components, check for the following conditions:

- *If stop/check valves are used, make sure that they are fully open.*
- *Make sure that the hot and cold inlet pipes are connected properly, and that there are no cross-connections or leaking stop/check valves.*
- *Check the hot water heater output to make sure that it is at least 20° F above the set temperature.*

Be sure to close the appropriate shut-off valves prior to disassembly of the valve and reopen the valves after inspection and repair is complete.

Problem: Limited water flow

Cause: Dirt and debris have built up in the valve or strainer.

1. Remove and clean strainer. If strainer needs to be replaced, order Bradley part no. 173-028.
2. Check the piston for smooth movement.

To check the valve's piston for free and smooth movement, follow the procedures outlined below:

1. Remove the valve's cap and thermostat (see Figure 10 on Page 20).
2. Push down on the piston with your finger (the piston should move freely). If the movement is not as it should be, the piston needs to be cleaned. Follow the method outlined below for cleaning the piston and valve body:
 - Remove the thermostat.
 - Lift the piston out with a needle-nose pliers and remove the spring.
 - Any cleaner suitable for brass and stainless steel may be used (if cleaning with suitable cleaner is not sufficient to remove debris, a 400-grit sandpaper may be used to polish and hone the piston and valve body).
 - Snap spring into piston (will detent) and reassemble into the valve body. Retest the piston.
3. If, after a thorough cleaning, the piston does not move freely, the piston must be replaced. Contact your Bradley representative and ask for Repair Kit (part number S65-259).

Problem: External leaks in the system

Cause: O-rings have been damaged.

Solution: Replace O-rings where necessary. For replacement of the O-rings, contact your Bradley representative and ask for Repair Kit (part number S65-259).

Problem: Improper water temperature or temperature fluctuation

Cause: Thermostat is slowly failing or not working at all.

Solution: Check the thermostat for proper operation.

1. At room temperature (80° F or less) remove cap and thermostat.
2. Place thermostat into container with 115° F water. The pushrod should pop out of the thermostat approximately 1/10".
3. If thermostat pushrod does not pop out, the thermostat must be replaced. Contact your Bradley representative and ask for Repair Kit (part number S65-259).

Cause: Valve temperature is not properly set.

Solution: Adjust the temperature. Using a blade screwdriver, turn the adjustment stem **counterclockwise** to **increase** the temperature or **clockwise** to **decrease** the temperature.

Vernatherm™ Thermostatic Mixing Valve S01-520

Repair Kit S65-259

Item	Qty	Description
2	1	Spring
3	1	Piston
4	1	Thermostat
6	1	O-Ring
7	1	O-Ring

10	2	Strainer (173-028)
----	---	--------------------

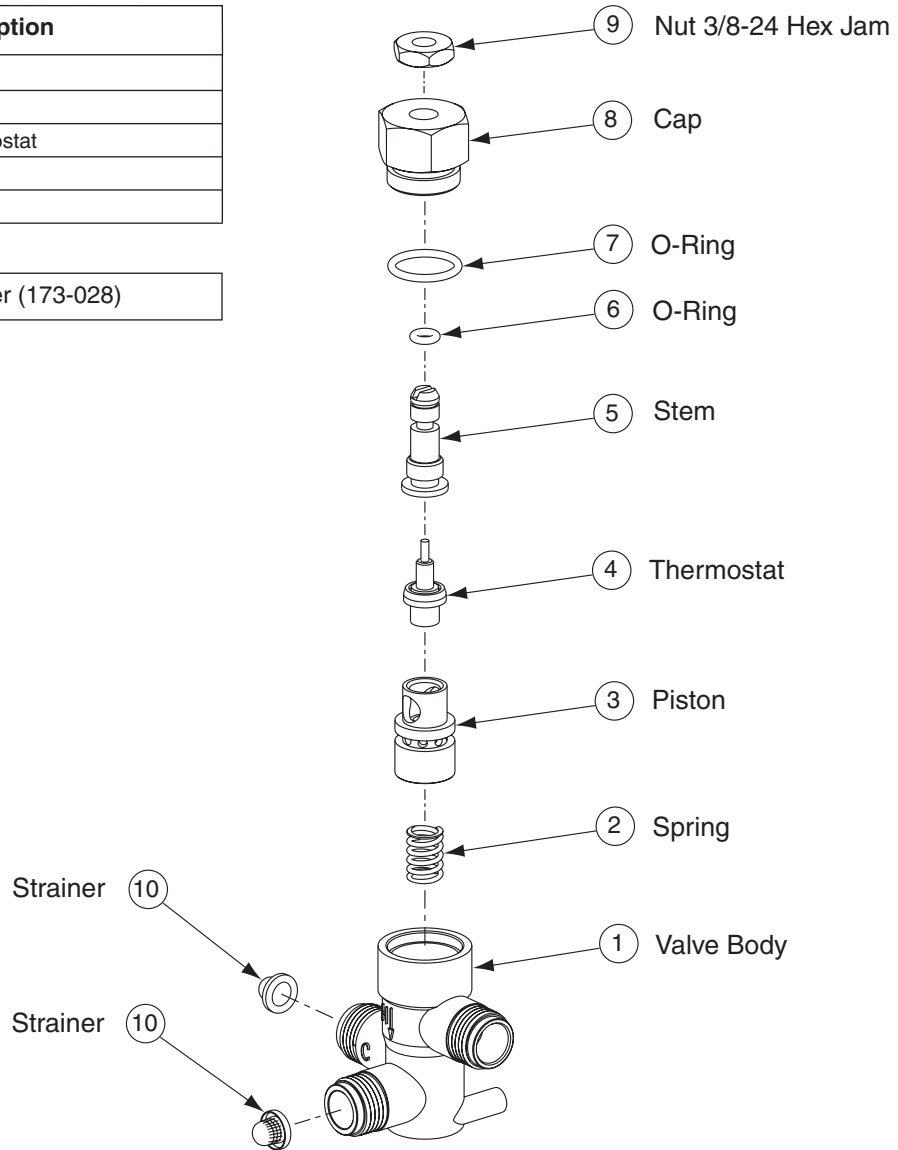

Figure 10