

MERIDIAN MODEL# 3792

CORTERRA ADA-COMPLIANT WASHFOUNTAIN

REQUIRED ITEMS FOR INSTALLATION – NOT SUPPLIED

- 7/16" Hex Wrench
- Plumbers Putty
- Teflon Tape
- Slotted Screwdriver (for Metering Adjustment)
- Socket and Driver for Center Reject Bit
- 3/8" Fixture Anchoring Hardware (and Appropriate Tools)



TRUE SIZE

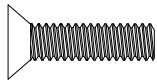

0152-006-000
10-32 UNF x 3/4" Center
Reject Hex Socket Flat
Head Screw – Qty. 12

0337-050-000
1/4" Lock Washer – Qty. 12
(For –ST option – Qty. 16)



TRUE SIZE

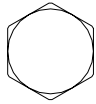

TRUE SIZE

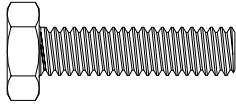

0206-002-000
1/4"-20 UNC x 1" Hex
Head Cap Screw – Qty. 4

0331-005-000
1/4" Flat Washer – Qty. 8
(For –ST option – Qty. 12)

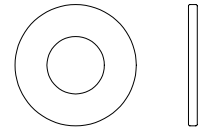

TRUE SIZE

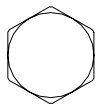

TRUE SIZE

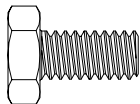

0206-004-000
1/4"-20 UNC x 1/2" Hex
Head Cap Screw – Qty. 4

0331-031-000
1/4" Fender Washer
Qty. 4

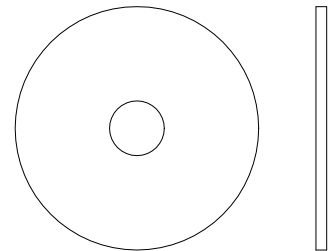

TRUE SIZE



TRUE SIZE

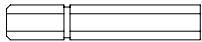

0296-025-199
Allen Head Bit With
Center Reject – Qty. 1

0302-005-000
1/4"-20 Hex Nut – Qty. 8
(For –ST option – Qty. 12)

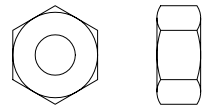

TRUE SIZE



ACORN ENGINEERING COMPANY

15125 Proctor Avenue • P.O. Box 3527
City of Industry • CA • USA • 91744-0527
Phone: 800.488.8999 Fax: 626.961.2200
Faxback: 888.226.7624 Web Site: www.acorneng.com
Field Service 800.743.8259



Some available options may affect installation procedures. Please review the entire manual before proceeding. Corterra and stainless steel should be protected throughout installation to prevent damage to surface finish. Refer to the Care and Cleaning section of this manual.

Rough-In Dimensions For Standard 34" Rim

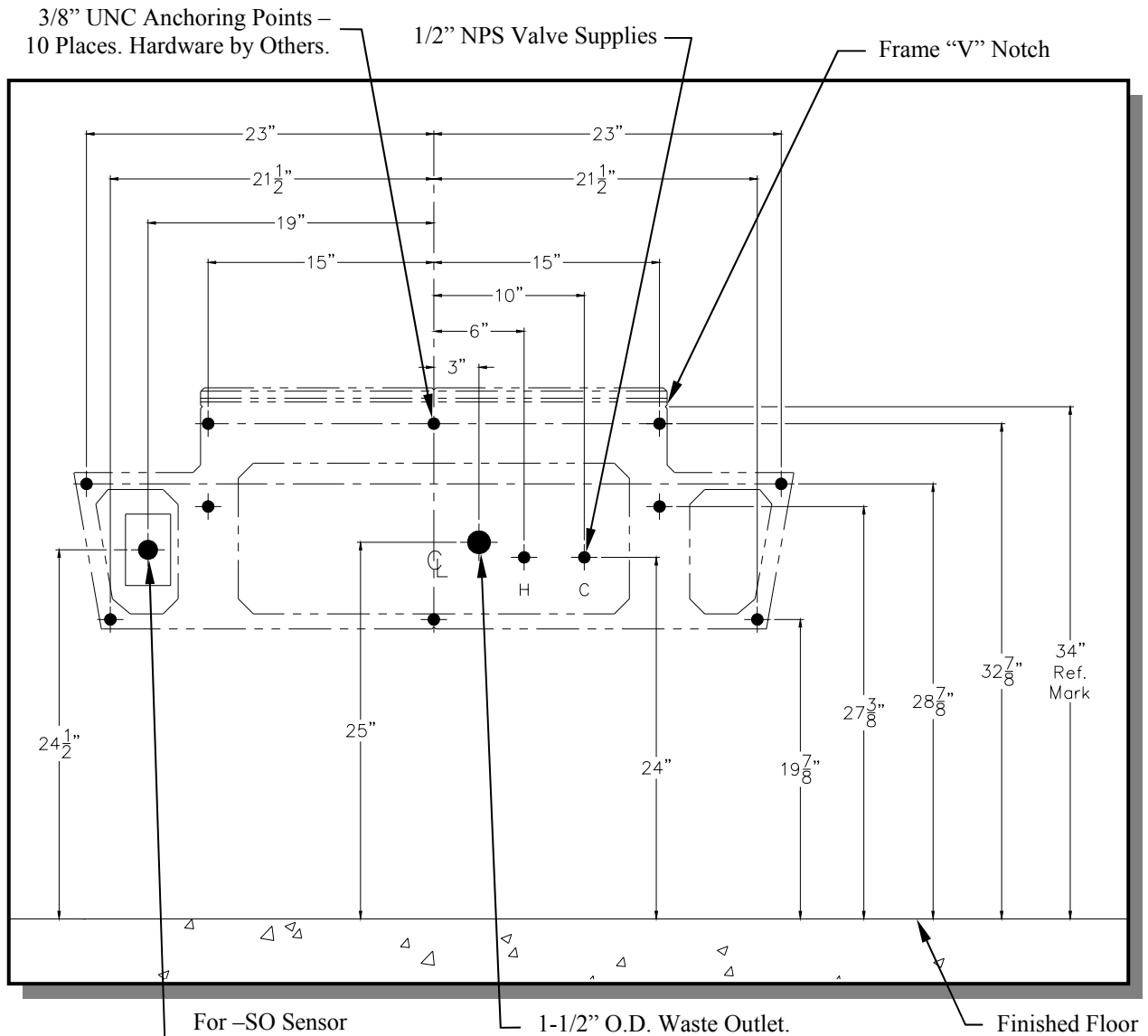

For -SO Sensor Operation: Supply 120V/60Hz 3 Amps (Max.) Electric Receptacle.



For lower rim heights, decrease vertical dimensions by subtracting the difference between standard 34" rim height and lower rim height from all dimensions. (i.e. For 30" rim height, decrease waste outlet height from 25" to 21", etc.)



1. Disassemble access panels and deck assembly from frame. Anchor frame to wall using 3/8" mounting hardware by others.

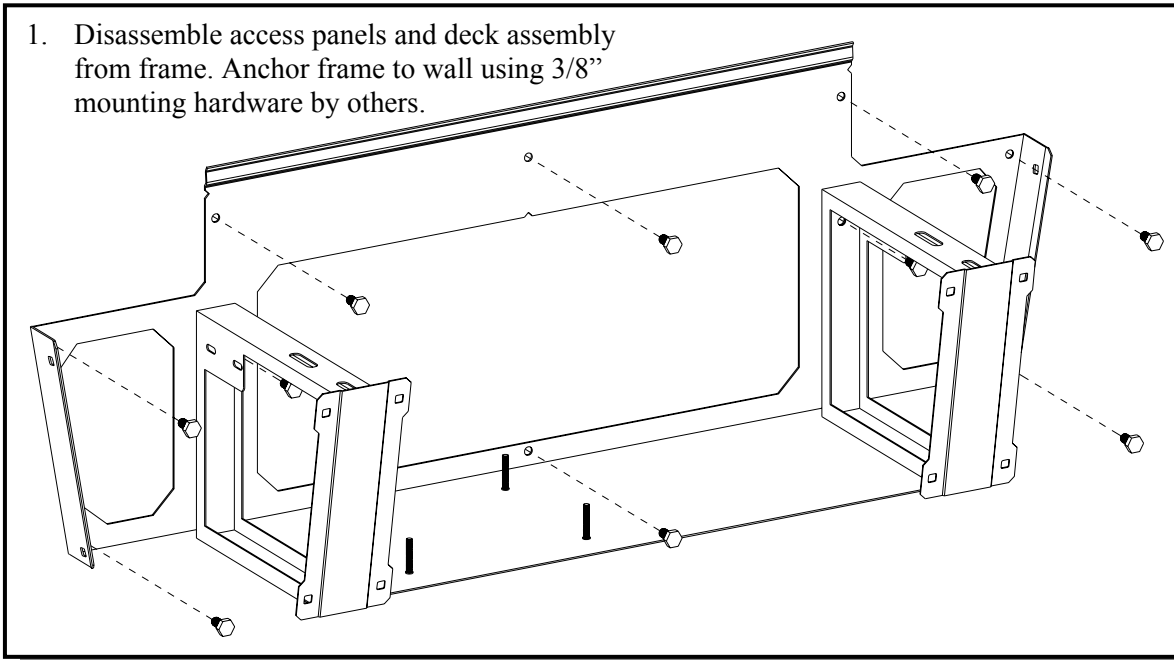

2. -See **DETAIL A**. Place deck assembly on frame, making sure angle engages behind frame joggle.
-See **DETAIL B**. Assemble underside of bowls to frame with 1/4"-20 x 1/2" hex bolts, 1/4" lock washers, and 1/4" fender washers provided.
-See **DETAIL C**. Assemble deck support flanges to outside of frame using 1/4"-20 x 1" hex bolts, 1/4" lock washers, and 1/4" flat washers provided.

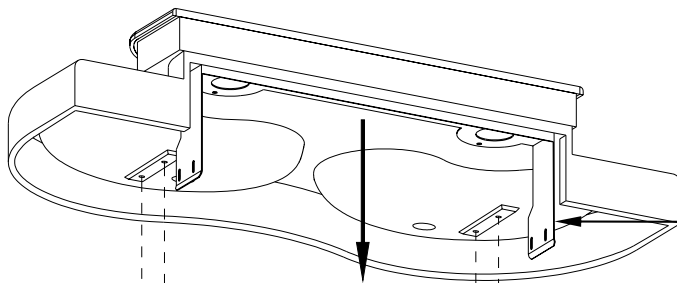
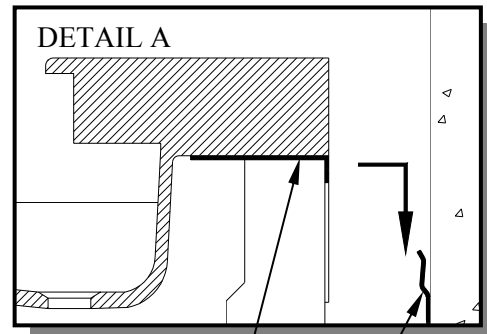

DETAIL B

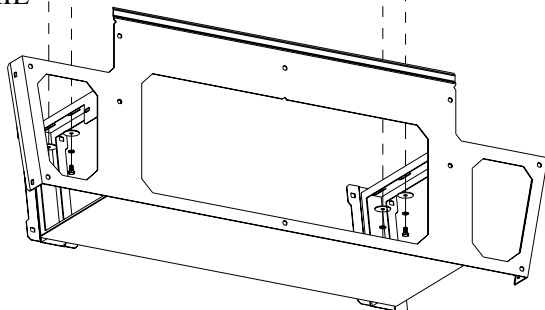

Angle
Frame Joggle

Deck Support Flanges

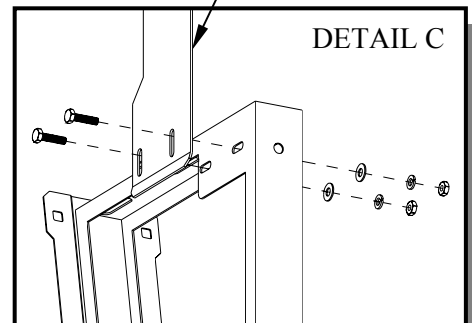



3. Install grid strainers with plumbers putty. Assemble waste piping using Teflon tape and make-up connection.

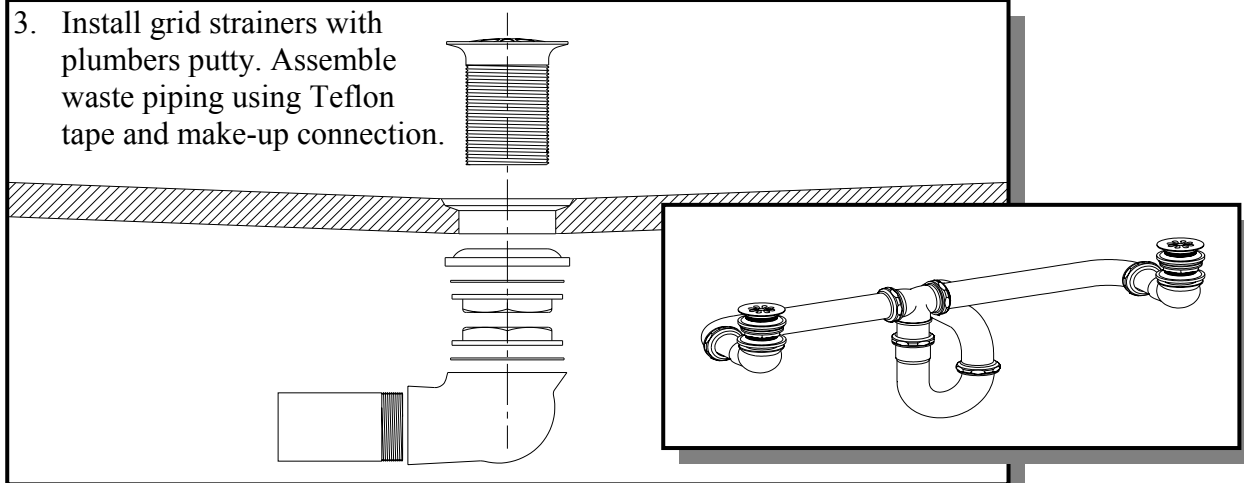

!IMPORTANT

Before making up the supply connections, the supply lines must be flushed of all foreign material such as pipe dope, pipe chips, solder, sand, etc.

!CAUTION!

VALVE RESTRICTIONS:
Maximum Pressure 100 PSI.
Max. Temperature 130° F.
Valve Outlet Temp. 105° F Max.

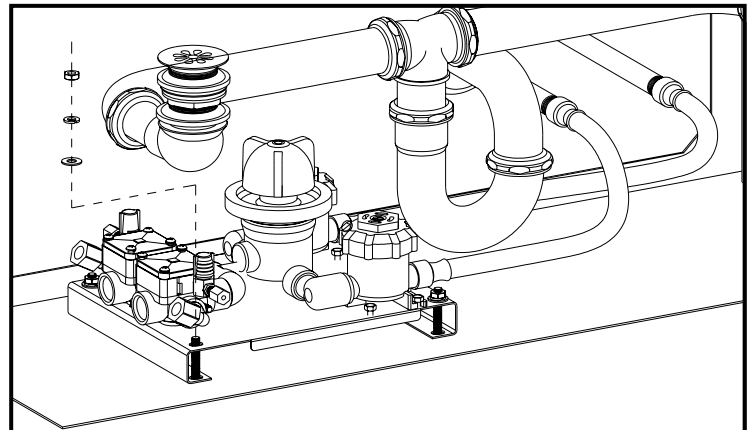

4A. For standard and -MXT valves, install valve using 1/4" lock washers, 1/4" flat washers and 1/4"-20 hex nuts provided. Flush supply lines. Connect valve.

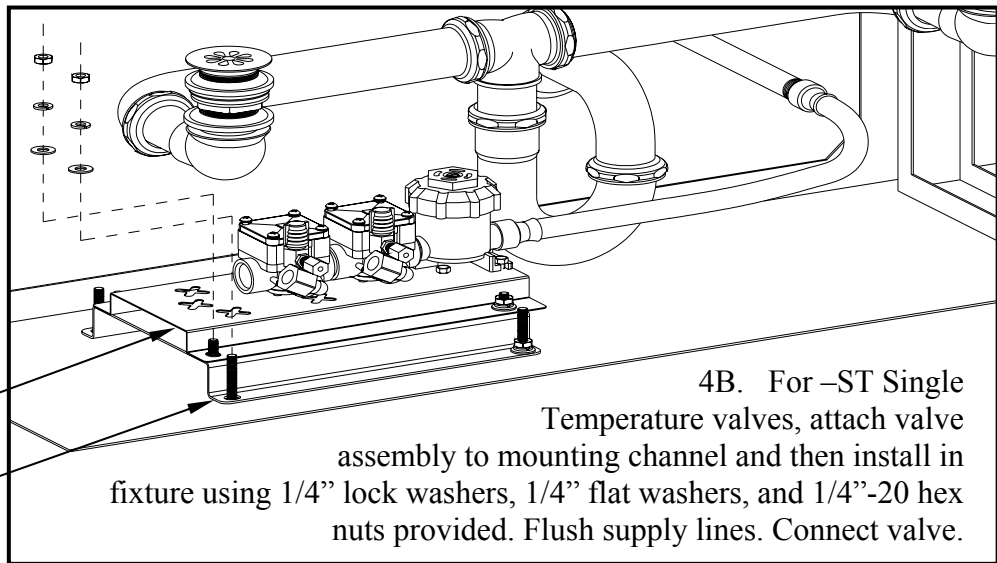

Valve Assembly

Mounting Channel

4B. For -ST Single Temperature valves, attach valve assembly to mounting channel and then install in fixture using 1/4" lock washers, 1/4" flat washers, and 1/4"-20 hex nuts provided. Flush supply lines. Connect valve.



-H Hand Operation

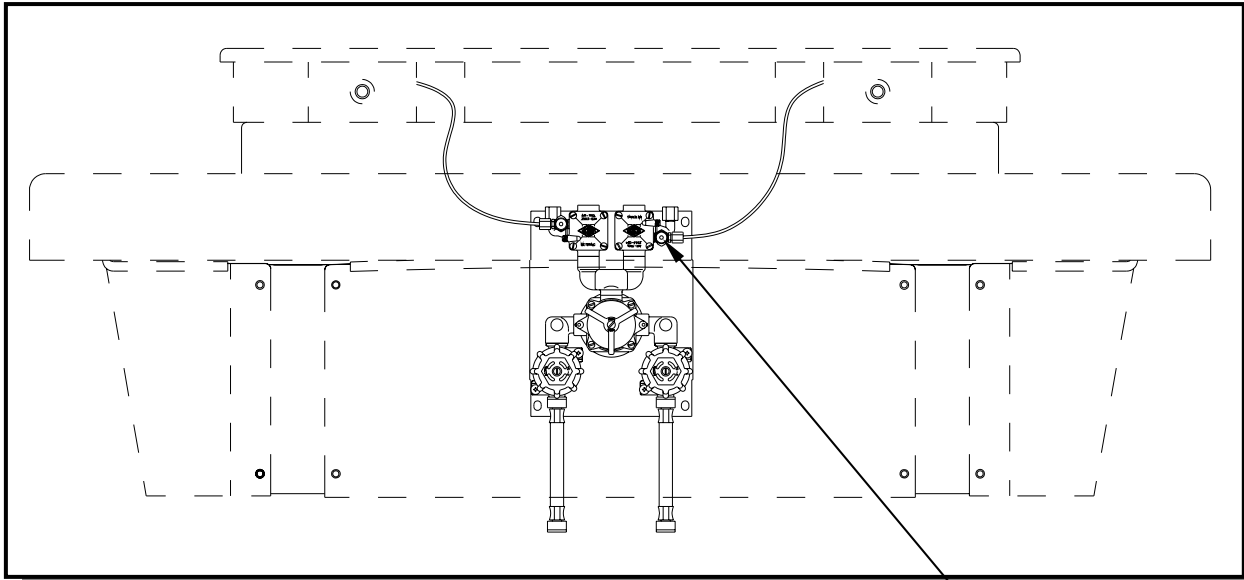

Valve Shown Upright For Reference Only

Ferrule Nut

Timing Screw.
Turn timing screw to adjust metering.

!IMPORTANT
Do not overtighten ferrule nuts.

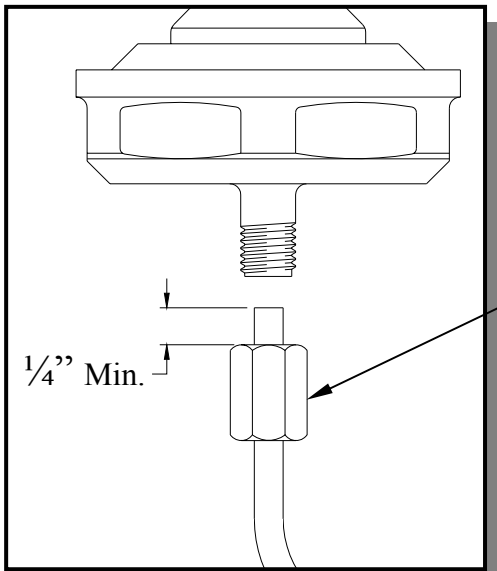
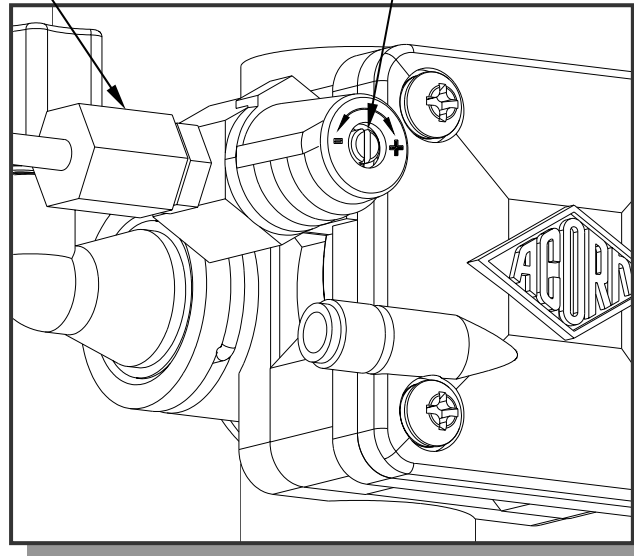

Ferrule Nut

 Turn timing screw clockwise to increase timing.

!IMPORTANT Leave a minimum 1/4" of polyethylene tubing through the Ferrule Nut on the pushbutton assembly. This is necessary to ensure proper tubing connection.



-SO Sensor Operation Range Adjustment

1. Make sure power supply is disconnected from sensor and make short circuit on red wires. See DETAIL A.
2. Connect power supply to sensor.
3. Move hand in front of sensor to distance of 2" to 4" within 5 seconds.
4. Wait until red light flashes quickly and move hand to desired sensing distance. See DETAIL B.
5. Hold hand at desired sensing distance until red light stops flashing. See DETAIL C.

Jumper
By Others

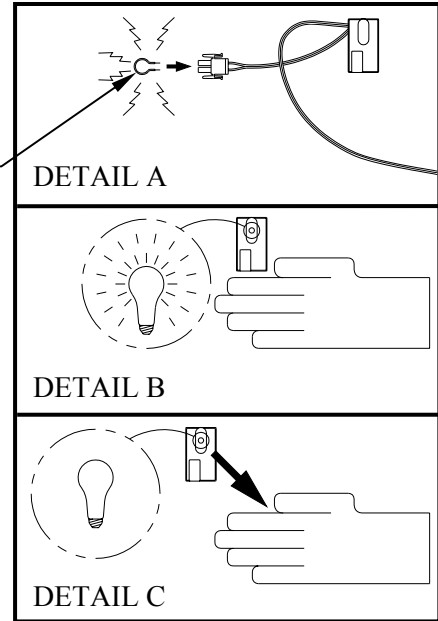

-SO Sensor Operation - Standard

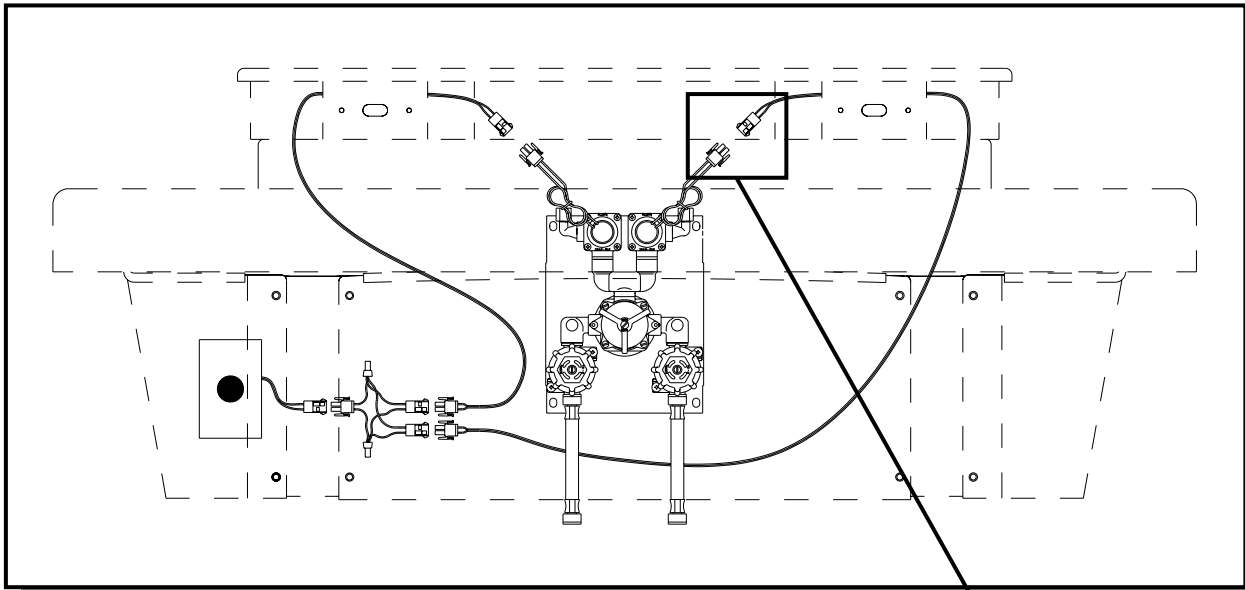

Valve Shown Upright For Reference Only

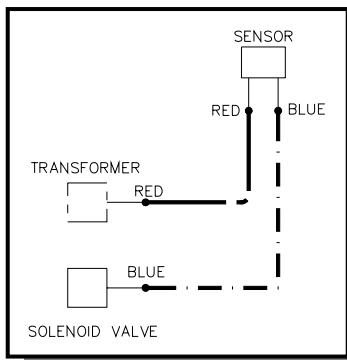

!IMPORTANT

Transformer must be plugged into a GFI protected circuit. Fixture must be earth grounded per N.E.C. or applicable codes.

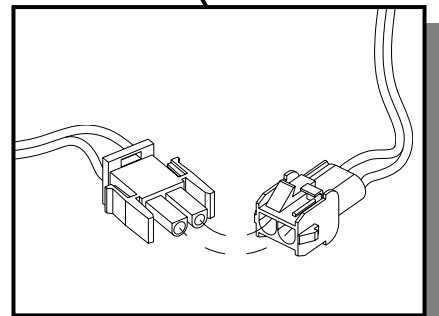



-SO-BAT Sensor Operation – Battery Powered

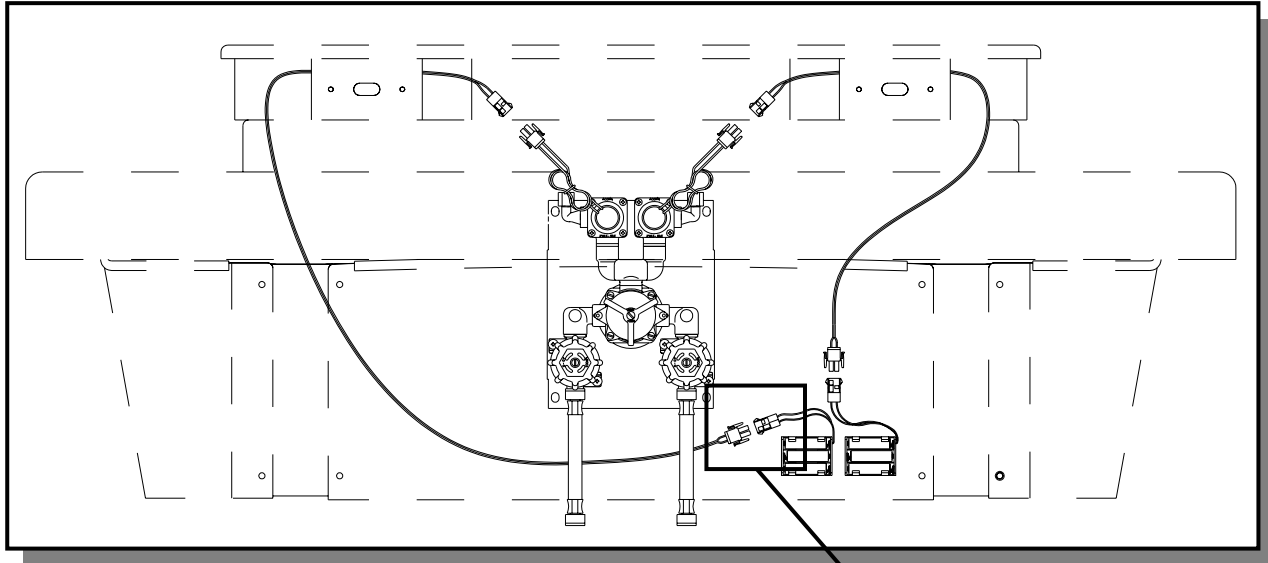

Valve Shown Upright For Reference Only

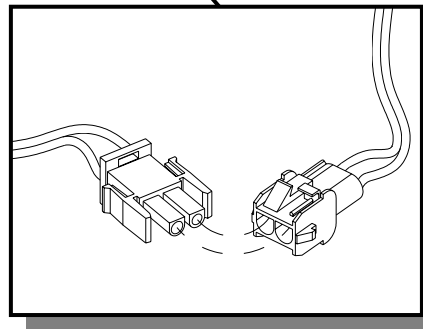
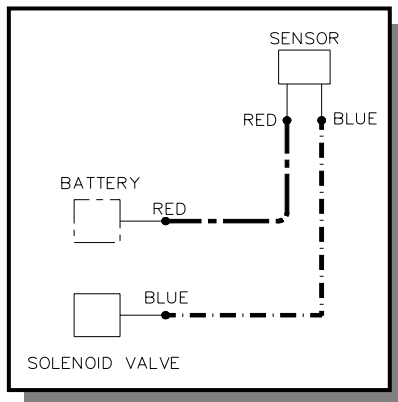

Acorn does not provide batteries for –BAT units. Each station requires (6) AA batteries.

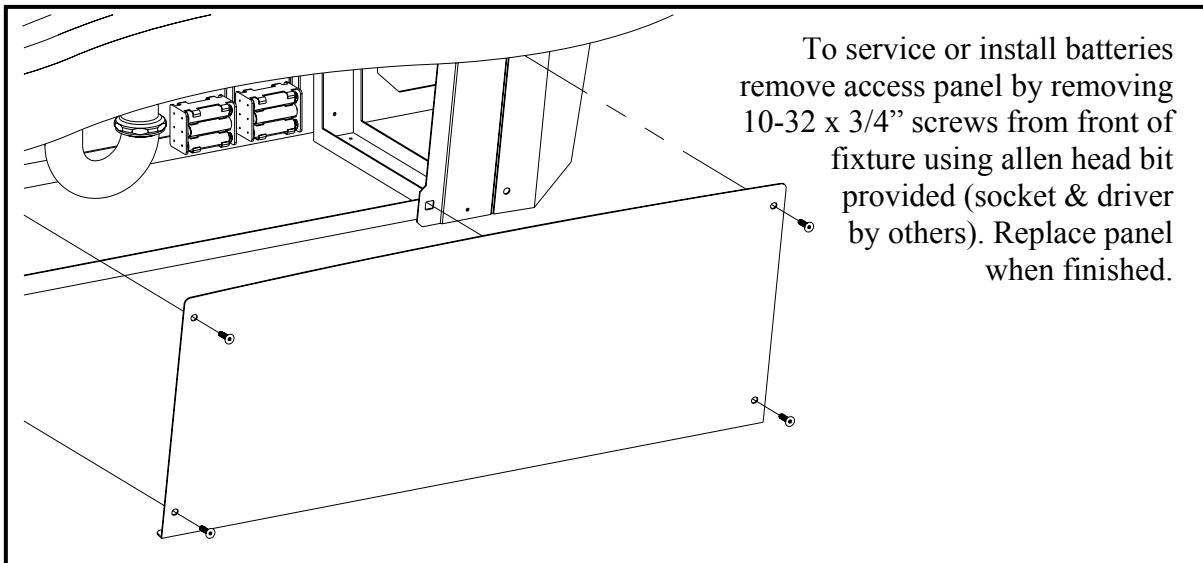



5. Install front and side access panels using 10-32 x 3/4" screws provided.

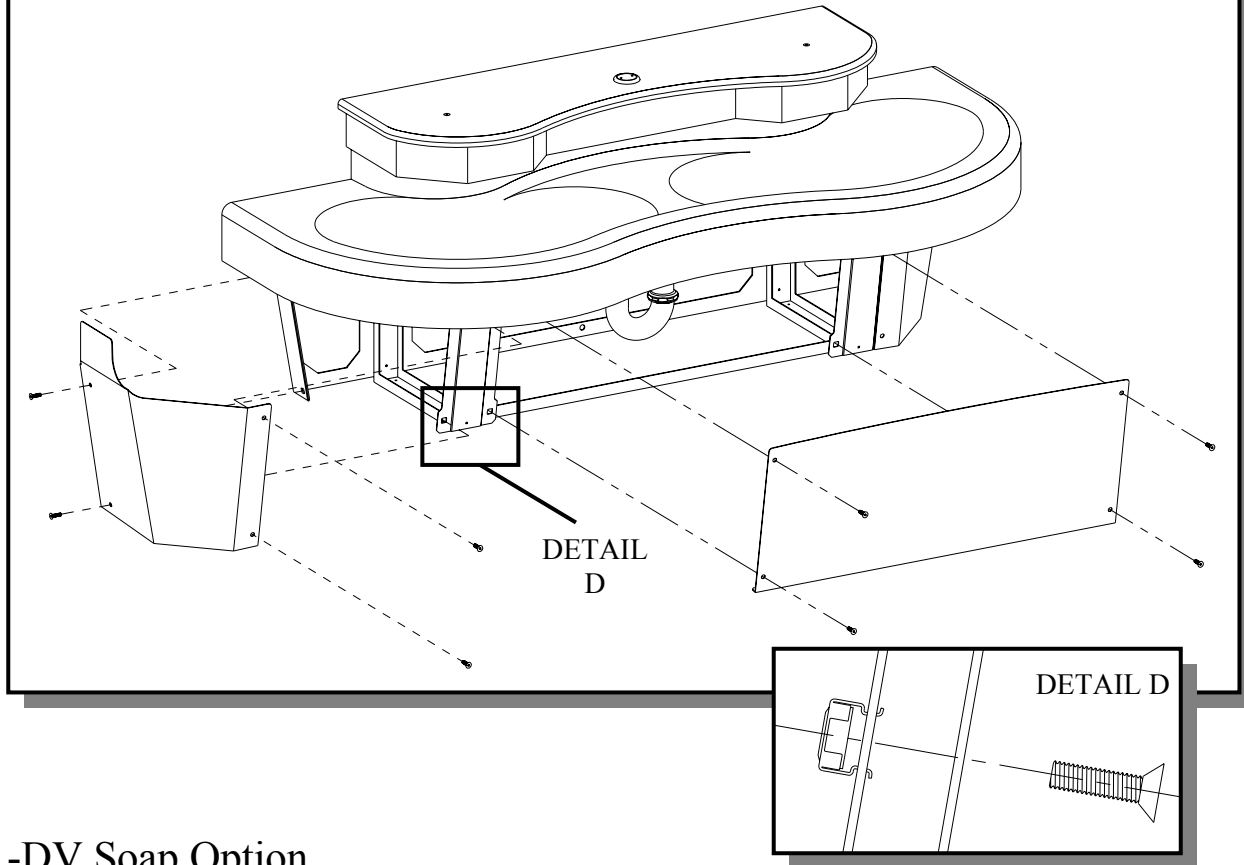

-DV Soap Option

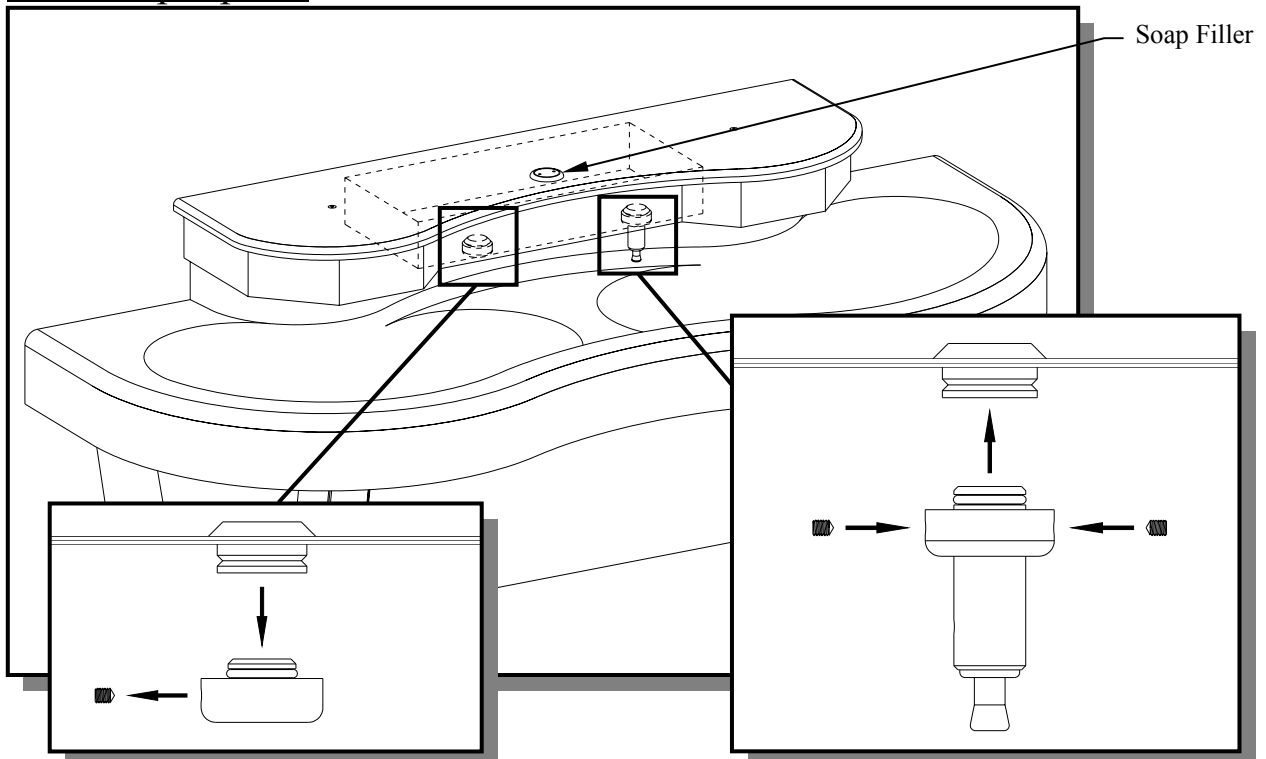



TROUBLE SHOOTING FOR HAND PUSHBUTTON OPERATED VALVES

Normal Valve Function: Hand pushbutton operated valve has an adjustable flow time of 5 to 60 seconds.

CONDITION: WATER DOES NOT FLOW

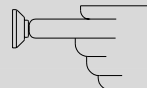
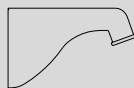

<i>Probable Cause:</i>	<i>Solution:</i>
Water Main Closed.	Open Water Main.
Checkstops Closed.	Open Checkstops.
Debris or Scale in Checkstop Strainer.	Remove Checkstop Strainer and Clean.
Air Leaks from 1/8" O.D. Tubing or Fittings.	Replace Damaged Tubing or Fitting.
Pushbutton Air Diaphragm Leaks.	Replace Pushbutton Air Diaphragm.
Servomotor Diaphragm Center Hole is Blocked.	Remove Blockage.
Servomotor Upper Diaphragm is Damaged.	Replace Servomotor Upper Diaphragm.
Low or No Water Pressure at Supplies.	Increase Water Pressure to 30 PSI Minimum.

CONDITION: WATER DRIPS, WON'T SHUT OFF

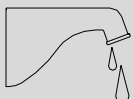

<i>Probable Cause:</i>	<i>Solution:</i>
Servomotor Diaphragm Offset Hole is Blocked.	Remove Blockage.
Servomotor Seat is Damaged.	Replace Servomotor Seat.
Servomotor Plate or Diaphragm is Obstructed.	Remove Cause of Obstruction.
Servomotor Timer Assembly is Damaged.	Replace Servomotor Timer Assembly.

CONDITION: REDUCED WATER FLOW

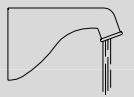

<i>Probable Cause:</i>	<i>Solution:</i>
Valve Riser Tubing is Crimped.	Straighten Valve Riser Tubing.
Debris or Scale in Checkstop Strainer.	Remove Checkstop Strainer and Clean.
Blockage in Valve Flow Control.	Remove Blockage.
Low Water Pressure at Supplies.	Increase Water Pressure to 30 PSI Minimum.
Lime Deposits in Hot Water Pipes.	Remove Lime Deposits with Appropriate Cleaning Solution.

CONDITION: PREMATURE WATER SHUT OFF.

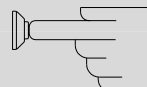
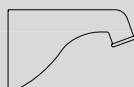

<i>Probable Cause:</i>	<i>Solution:</i>
Air Leaks from 1/8" O.D. Tubing or Fittings.	Replace Damaged Tubing or Fitting.
Pushbutton Air Diaphragm Leaks.	Replace Pushbutton Air Diaphragm.

MINIMUM / MAXIMUM WATER PRESSURE (PSI) 30 / 100. MAXIMUM WATER TEMPERATURE 130°F.



TROUBLE SHOOTING FOR 9 VOLT DC SENSOR OPERATED VALVES

Normal Valve Function: 9 Volt DC sensor operated valve has flow time of 90 seconds maximum. To reactivate, the user must move out of and return to the sensing area.

CONDITION: WATER DOES NOT FLOW

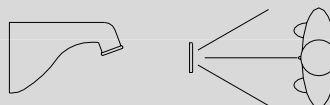

<i>Indicators:</i>	<i>Probable Cause:</i>	<i>Solution:</i>
Sensor Flashes Continuously Every 2 Seconds When Hands are Within Range.	Low Battery Warning.	Replace Battery.
Sensor Does Not Flash When the User's Hands are Within Range.	Circuit Breaker Tripped.	Reset Circuit Breaker.
	Battery Completely Used Up.	Replace Battery.
	Defective 9VDC Transformer.	Replace Transformer.
	Transformer Polarity Crossed.	Replace Transformer (Sensor may be Damaged and Need Replacement).
	Unit is in "Security Mode" After 90 Seconds of Constant Detection.	Remove Sources of Detection and Wait 30 Seconds Before Checking.
	Range is too short.	Increase Range.
	Range is too long.	Decrease Range and Wait 30 Seconds.
	Sensor is Picking Up a Highly Reflective Surface.	Eliminate Cause of Reflection and Wait 30 Seconds Before Checking.
Sensor Flashes Once When User's Hands are Within Range.	Defective Sensor.	Replace Sensor.
	Stops or Water Main Closed.	Open Stops or Water Main.
	Bad Sensor to Solenoid Connection.	Ensure Wires make Proper Contact.
	Debris or Scale in Solenoid Assembly.	Remove Solenoid, Pull Out Plunger and Spring, and Clean with Scale Remover Solution or Pressurized Air.
	Debris or Scale in Diaphragm.	Remove Diaphragm and Clean
	Debris or Scale in Strainer.	Remove Strainer and Clean.

CONDITION: FALSE TRIGGERING;
WATER FLOWS CONTINUOUSLY



<i>Indicators:</i>	<i>Probable Cause:</i>	<i>Solution:</i>
Sensor Flashes when User's Hands are Within Range.	Debris or Scale in Diaphragm.	Remove Diaphragm and Clean.
	Diaphragm is Defective or Torn.	Replace Diaphragm.
Sensor Does Not Flash when User's Hands are Within Range.	Sensor is Dirty or Covered.	Clean or Uncover Sensor and Wait 30 Seconds.
	Range too long or Highly Reflective Surface, Sunlight, Bright Lights etc. are Triggering Sensor.	Decrease Range and Wait 30 Seconds.
		Eliminate Cause of Reflection or Correct Lighting Problem.

CONDITION: WATER FLOWS CONTINUOUSLY BUT STOPS WHEN HANDS ARE WITHIN RANGE

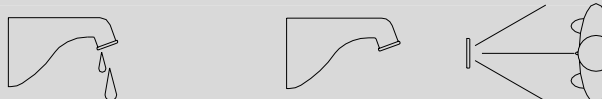





<i>Indicators:</i>	<i>Probable Cause:</i>	<i>Solution:</i>
Water Runs Continuously When Sensor Not Activated. Sensor Flashes When Hands are Within Range and Water Shuts Off.	Solenoid Polarity Crossed.	Disconnect Solenoid and Reverse Polarity.

MINIMUM / MAXIMUM WATER PRESSURE (PSI) 30 / 100. MAXIMUM WATER TEMPERATURE 130°F.

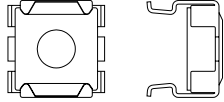
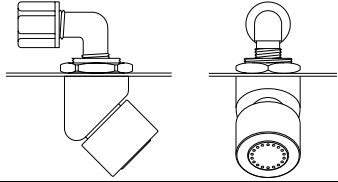
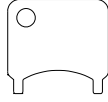
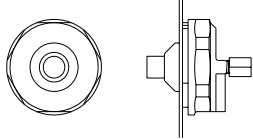
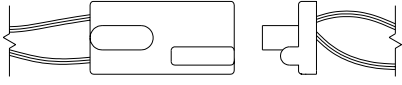

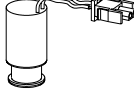

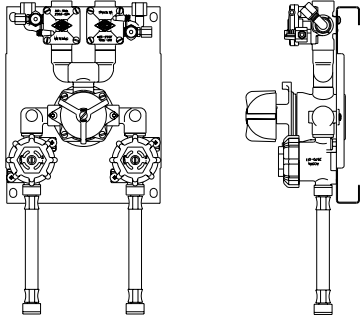
REPAIR PARTS

Description	Part No.	Diagram
#10-32 UNF Stainless Steel Nut Retainer	0316-018-000	
SPOUTS		
Nozzle Assembly	6214-005-001	
Spanner Key for Spout Aerator and Soap Filler	2998-055-199	
-H SPOUTS		
Push Button Assembly	2566-050-001	
-SO HARDWARE		
Sensor Assembly	2562-373-001	
9 VDC Plug-In Transformer	0711-410-001	
9 VDC Solenoid	2563-326-001	
9 VDC Sensor Power Battery-Pak Assembly (Less Batteries)	0710-357-001	
VALVES		
-H Hand Operated Pressure Balancing Mixing Valve Assembly	2595-602-001	<p>-H Hand Operated Pressure Balancing Mixing Valve #2595-602-001 shown.</p> 
Optional -H-MXT Thermostatic Mixing Valve Assembly	2595-592-001	
Optional -H-ST Single Temperature Valve Assembly	2595-612-001	
-SO Sensor Operated Pressure Balancing Valve Assembly	2595-632-002	
Optional -SO-MXT Sensor Operated Thermostatic Mixing Valve Assembly	2595-622-002	
Optional -SO-ST Sensor Operated Single Temperature Valve Assembly	2595-642-002	

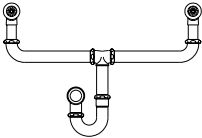

REPAIR PARTS (CONTINUED)

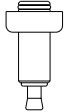
Description	Part No.	Diagram
P-Trap	4970-008-001	
SOAP SYSTEM		
Optional –DV Soap Tank	6214-006-001	
Soap Dispenser Pump	6214-009-001	

CARE, CLEANING, AND REPAIR OF CORTERRA SOLID SURFACE

Corterra should be kept clean at all times. If maintained, Corterra surfaces will retain their new, clean appearance indefinitely. In order to remove any unwanted stains, wash with soapy water then rinse. In order to prevent water stains from occurring, dry surface right after rinsing. If the stain persists, use a Scotch Brite® pad and an abrasive cleaner, or you can also use a solution consisting of household bleach and water (1 part water to 1 part bleach). To avoid any water marks, wipe surface dry. To remove cuts and scratches use 400 grit sandpaper, followed by an abrasive cleaner and Scotch Brite® pad. In order to repair chipped Corterra (using repair kit available from Acorn) do the following:

- Put on gloves prior to handling any of the materials in the kit, and ensure adequate ventilation.
- Add contents of “B” (liquid resin) to larger container “A” (solid filler). Mix completely using wooden stick.
- Add tube of “C” (liquid catalyst). Mix for two (2) minutes. CAUTION: Catalyst gel time at 75° is 15 minutes.
- Apply mixed material to damaged area using wooden stick. NOTE: Apply only as much patch as required.
- Let cure approximately 3-4 hours. NOTE: For a "fast cure" of approximately 10 minutes, use a lamp with a 100 watt light bulb shining on patched area about 2-1/2" from patch.
- Use coarse grained sandpaper to sand off extra material once patch is hard.
- Use medium grained sandpaper for finer finish.
- Use fine grained sand paper for "polished" look finish.
- Discard extra patch material appropriately.

WARNING: Flammable. Keep away from heat, sparks, and open flame. Avoid contact with skin and wash with soap and water after skin contact. In case of eye contact, flush with water for 15 minutes and get medical attention. Harmful if swallowed. Keep out of reach of children.

CARE AND CLEANING OF STAINLESS STEEL SURFACE

Stainless steel should be kept clean at all times. If maintained, stainless steel surfaces will retain their new, clean, polished appearance indefinitely. To remove water spots or rust spots, stainless steel cleaner/polish on a cloth is recommended. IF SPOTS ARE STUBBORN OR IF YOU WISH TO TREAT A SCRATCH: synthetic, abrasive, general-purpose pads such as Scotch Brite® are recommended. Apply the stainless steel cleaner/polish to the synthetic, abrasive pad and CAREFULLY rub out spot with cleaner/polish. **Be sure to rub in the direction of the grain!** Do not allow steel wool to come in contact with stainless steel. Steel particles can embed into the stainless steel surface and create rust!

WARRANTY INFORMATION

Acorn warrants that all of its products are guaranteed against defective material or poor workmanship for a period of one year from date of shipment. Acorn's liability under this warranty shall be discharged by replacing without charge F.O.B. City of Industry, California, any goods, or part thereof, which appears to the company upon inspection to be of defective material or not of first class workmanship, provided that claim is made in writing to the company within reasonable period after receipt of the product. Where claims for defects are made, the defective part or parts shall be delivered to the company, prepaid, at City of Industry, California for inspection. Acorn will not be liable for the cost of repairs, alterations or replacement, or for any expense connected therewith made by the owner or his agents, except upon written authority from the Acorn City of Industry office. Acorn will not be liable for any damages caused by defective materials or poor workmanship, except for replacements, as above provided. Contact local Acorn Representative for complete terms and conditions.